

UNIVERSAL HARNESS

ADAPTER FOR PLUG AND PLAY HEADLIGHT MODULE INSTRUCTIONS

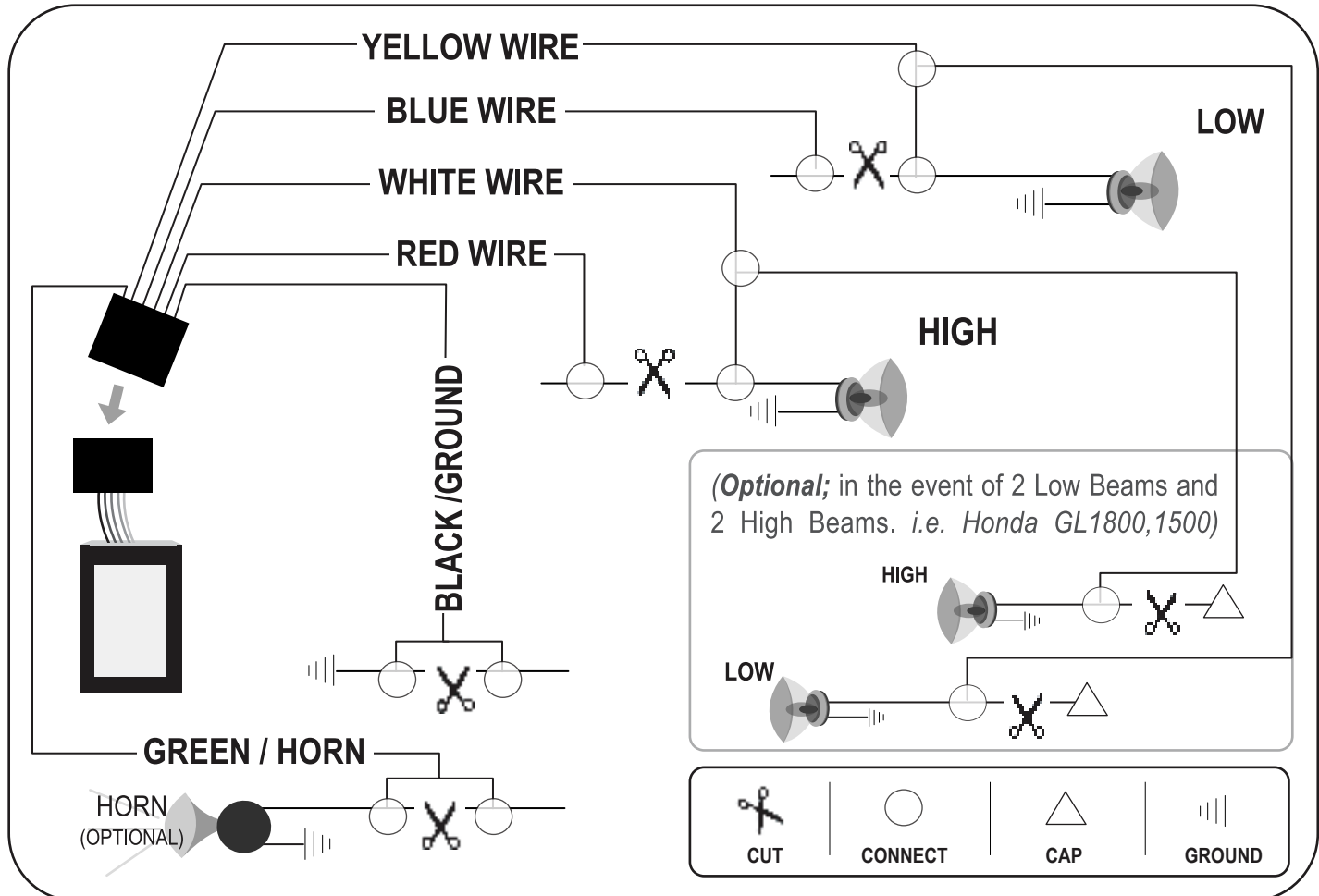

TO INSTALL:

1. Check to make sure your high beams and low beams are functioning properly.
2. Locate positive lead for both low and high beams.
3. Find a suitable location to cut the leads in 2. Strip 1/4" of insulation to place wiring into provided squeeze lock clips.
4. Locate a ground lead, cut into two pieces and Strip 1/4" of insulation and place wiring into provided squeeze lock clips.
5. *This step is optional. If you would like to utilize the "Heads-Up" Alert feature proceed, if you prefer not to just skip to step 6.* Use the included blue tap splice connector to connect the green wire from the H4 Single Harness to the bike's horn wire. The bike's horn wire is the wire that connects the bike's horn button to the bike's horn. Note: there only two wires on the horn itself and one of them is where the green wire connects. Choosing the wrong wire will not harm the module or the bike in anyway; the Heads Up Alert feature just will not work.

6. Mount the optic sensor in a water protected area facing the road. Under the fairing pointed at the front fender is usually a good location. For those who would like a more permanent installation of the "Day Light Sensor", a 5/16 hole can be drilled into fairing. Otherwise, it can be secured to one of the bikes wires or cables with the enclosed zip tie.(Refer to diagram below)

7. Mount the Headlight Module with the enclosed adhesive pad and secure all wiring in a manner that will not interfere with any of the bike's controls.

Note: there are only two wires on the horn itself and one of them is where the green wire connects. Choosing the wrong wire will not harm the module or the bike in anyway; the Heads Up Alert feature just will not work.

Also: Fluorescent or LED lighting will not activate the module; to test use an incandescent light source or move outdoors.

