



SML RED FENDER MOUNT SILVER BULLETS 1650

PARTS INCLUDED

- 2 Small LED Silver Bullets
2 Short Fender Strut Mounts
1 Hardware Kit
4 3/8" Chrome Flat Washers
2 5/16-18 x 1" Button Socket Cap Screws
2 5/16 x 2-1/4" Hex Head Cap Screws
2 3/8-16 x 1-1/8" Hollow Hex Head Screws
2 Anti-Rotation Pins
2 3/8-16 Nylon Locking Nuts
1 Anti-Seize
1 Load Equalizer
3 Wire Connectors
1 Installation Instructions

Please read and understand entire instructions before starting installation.

THANK YOU FOR CHOOSING KÜRYAKYN!

IN ORDER TO PROTECT YOU AND OTHERS FROM POSSIBLE INJURY AND/OR PROPERTY DAMAGE OR LOSS, PLEASE PAY CLOSE ATTENTION TO ALL INSTRUCTIONS, WARNINGS, CAUTIONS AND ATTENTION NOTES REGARDING THE USE AND CARE OF THIS PRODUCT.

WARNING! THIS INDICATION ALERTS YOU TO THE FACT THAT IGNORING THE CONTENTS DESCRIBED HEREIN CAN RESULT IN POTENTIAL DEATH OR SERIOUS INJURY.

CAUTION! This indication alerts you to the fact that ignoring the contents described herein can result in potential injury or material damage.

ATTENTION! This indication alerts you to the fact that ignoring the contents described herein may negatively affect product performance and functionality.

TOOLS SUGGESTED

Set of Hex Wrenches, Combination Wrenches, Wire Cutter/Stripper, Test Light

STRICTLY OBSERVE THE FOLLOWING GUIDELINES IN ORDER TO USE THE PRODUCT PROPERLY AND AVOID POTENTIALLY DANGEROUS ACCIDENTS.

PROCEDURE

STEP 1 Read and understand all steps in the instructions before starting the installation. Park the motorcycle on a hard, level surface; turn off the ignition and allow the engine to cool.

ATTENTION! Be sure to use the supplied anti-seize on all threaded fasteners before installation. This will reduce galling and make future removal of the fasteners easier.

NOTE

Silver Bullets are not D.O.T. approved and are intended for use as auxiliary running, turn, or brake lights only.

CUSTOMER SERVICE
877.370.3604 (toll free)

INSTALLATION QUESTIONS
techsupport@kuryakyn.com
or call 715.247.2983

LIMITED WARRANTY

Kuryakyn warrants that any Kuryakyn products sold hereunder, shall be free of defects in materials and workmanship for a period of one (1) year from the date of purchase by the consumer excepting the following provisions:

- Kuryakyn shall have no obligation in the event the customer is unable to provide a receipt showing the date the customer purchased the product(s).
The product must be properly installed, maintained and operated under normal conditions.
Kuryakyn makes no warranty, expressed or implied, with respect to any gold plated products.
Kuryakyn shall not be liable for any consequential and incidental damages, including labor and paint, resulting from failure of a Kuryakyn product, failure to deliver, delay in delivery, delivery in nonconforming condition, or for any breach of contract or duty between Kuryakyn and a customer.
Kuryakyn products are often intended for use in specific applications. Kuryakyn makes no warranty if a Kuryakyn product is used in applications other than intended.
Kuryakyn electrical products are warranted for one (1) year from the date of purchase by the consumer. Components of Kuryakyn products containing L.E.D.s will be warranted for defects in materials and workmanship for 3 years from the date of purchase.
Kuryakyn makes no warranty of any kind in regard to other manufacturer's products distributed by Kuryakyn. Kuryakyn will pass on all warranties made by the manufacturer and where possible, will expedite the claim on behalf of the customer, but ultimately, responsibility for disposition of the warranty claim lies with the manufacturer.

ABOUT OUR CATALOG

You'll find all our innovations for H-D, GL and Metric Cruisers in our annual catalogs. Order online today-select the "CATALOGS" icon. Each Kuryakyn product comes with a Proof-of-Purchase good for a complimentary catalog. Details in packaging.

Be sure to ask your local dealer about other Kuryakyn products, the motorcycle parts and accessories designed for riders by riders.

©2005 Kuryakyn USA All Rights reserved.



FIG. 1

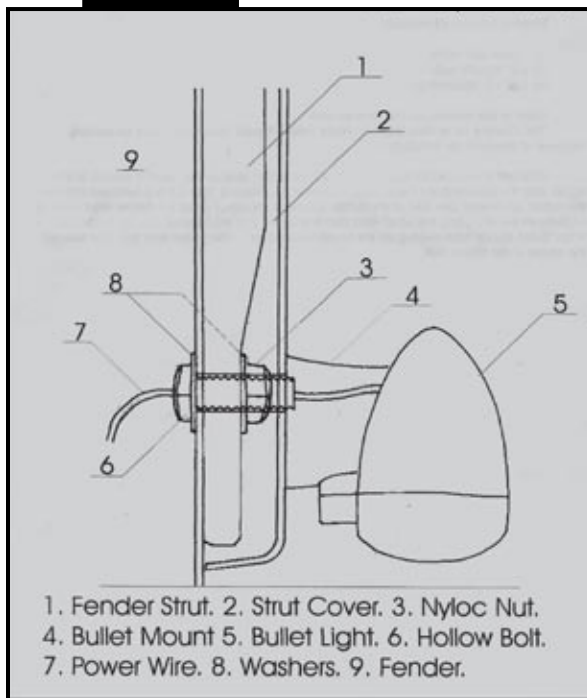
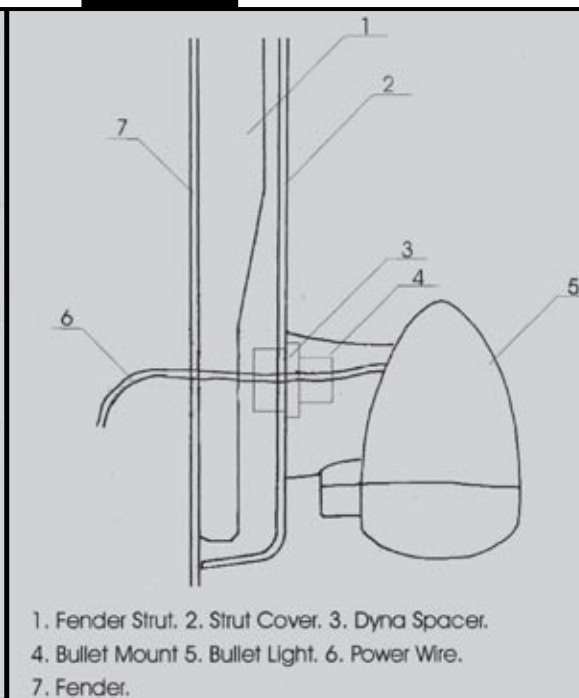

FIG. 2



The Red LED Kit P/N 1619 can be used as turn signals OR as running, turn and brake lights with the addition of our Run/Turn/Brake Controller P/N 4859 (sold separately).

**STEP 2** Remove the stock turn signals and mounts from the fender struts. Disconnect or cut the stock wires at a location that permits easy, clean, and out of the way splices. (Keep in mind the movement of the rear wheel as the suspension cycles.)

**STEP 3** See FIG. 1 for Softtails and FIG. 2 for Dyna Models. The line drawings show how the respective anti-Rotation devices are installed.

**STEP 4** Softtail Models, insert the hollow bolt from inside the fender, with the flat washers and Nylock nut placed exactly as in the drawing. The small amount that the hollow bolt protrudes through the fender strut keeps the mount from rotating.

**STEP 5** Install the appropriate assembly on your motorcycle. Securely tighten the mounting bolt. '00-'02 Softtail Models: The Silver Bullet and mount will attach to the chrome fender strut cover only with the 5/16"–18 x 1" Button Head Cap Screw (B.H.C.S.) provided, rather than using the 2-1/4" bolt pictured.

#### PROCEDURE FOR SINGLE CIRCUIT WIRING

**STEP 1** Locate the rear turn signal wires.

**STEP 2** Turn key on. Using a test light, check for power to the wires with applicable turn signal activated.

**CAUTION!** Any grounded wires will cause a short circuit. Make certain exposed wires are not grounded.

**STEP 3** Solder or connect the black wire from the Silver Bullet to the corresponding OEM turn signal wire. The housing of the Silver Bullet must be grounded to the frame or chasis.

#### SILVER BULLET WIRING:

Black Wire — Power (Hot)

Silver Bullet Housing — Ground

Test the lights for run and flash functions. If they light, but do not flash in the turn mode, add the load equalizer. The load equalizer has one black and two violet wires. The violet wires are not side specific.

-cont.-

**NOTE** LED Turn Signals require the use of one Load Equalizer PERer PAIRr OF LEeD TURurN SIGNALS to achieve the proper flash function. It is perfectly normal for the equalizer to get warm (about 140 degrees) during turn signal operation.

### **LOAD EQUALIZER WIRING**

**CAUTION!** Do not secure the load equalizer to the control module! Excess heat from the load equalizer could damage the control module.

**CAUTION!** Always install the load equalizer upstream of any existing aftermarket multifunction control modules. Do not install a load equalizer between a module and the turn signals as this will overload the module. Overloading will damage the module and create a fire hazard!

**CAUTION!** Load equalizers generate heat when in use. Avoid using the turn signals for an extended period of time, otherwise the load equalizer will overheat. Never operate the four-way flashers unless you first remove the load equalizer.

Overheating damages the load equalizer causing loss of turn signal operation and could create a fire hazard! When hard wiring the equalizer directly into the OEM wires you will need to cut off the plug-in on the equalizer. The load equalizer should be installed under the seat or where the rear taillight harness is located (side cover). Connect one each of the equalizers two violet wires to the bikes left and the other violet wire to the right turn signal positive wires. The black wire on the equalizer is connected to one of the black lighting ground wires, or to a bare metal chassis ground.

Load equalizers generate heat under normal use. It is important to tuck the load equalizer neatly out the way so it does not come in contact with any of the bike's heat sensitive components. Ideally, it should be fastened to the frame to help dissipate heat.

**CAUTION!** Do not operate the four way flashers (parade riding, etc.) as the equalizer will overheat and fail.

**Kuryakyn**<sup>®</sup>

**PAGE**

**3**