

Items Supplied >

1 - FRONT & 1 - REAR HEADPIPE / HEATSHIELD
1 - EXHAUST MOUNTING BRACKET
1 - MUFFLER ASSEMBLY
1 - EXHAUST VALVE ACTUATOR BRACKET
1 - EXHAUST VALVE ACTUATOR SOLENOID CAM
2 - FLANGE, HEADPIPE
6 - CLAMP, HS 24; 1 - CLAMP, HS 28
2 - CLAMP 27-61 (MUFFLER CLAMP)
2 - SPACER, ALUMINUM
2 - BOLT, 6 mm x 50 mm;
4 - BOLT, FLANGE 5/16" X 5/8"
2 - WASHER, 1/4" FLAT
2 - WASHER, 5/16" FLAT
2 - NUT, 6 mm
2 - NUT, 5/16"

Application(s) >

SUZUKI M109 1800 cc 2006 - 2009

Instruction Manual >

3481B

Page 1 of 4

ATTENTION: READ ALL INSTRUCTIONS CAREFULLY AND COMPLETELY BEFORE INSTALLING YOUR NEW EXHAUST SYSTEM, AVOIDING TO DO SO MAY RESULT IN DAMAGE TO YOUR MOTORCYCLES COMPONENTS. PRIOR TO INSTALLATION, MAKE SURE YOUR STOCK HEADPIPE GASKETS ARE IN GOOD CONDITION. IF YOU HAVE ANY DOUBTS AS TO THEIR CONDITION, REPLACE THEM.

1. Remove the seat and right side fairing cover (with M109 insignia), behind the fuel tank. To remove the fairing, release the plastic peg on top by pushing the center inward and pulling the fairing upwards until the peg releases, remove the M6 button head bolt at the bottom of the fairing. Pull the fairing outward from the rear and upward near the plastic peg to release it. Once it is free from all plastic pegs pull it forward to release it from the bottom of the fuel tank.
2. Remove the right side cover above the exhaust-mounting bracket secured by one M6 button head bolt, retain bolt for later. Remove the chrome steel cover above the exhaust secured by two remaining bolts; retain bolts for reinstallation of cover.
3. Locate the exhaust valve actuator solenoid and harness and disconnect the black 3-prong electrical connector and white 2-prong electrical connector.
4. Remove the allen bolts securing exhaust flanges to cylinder heads, set these fasteners aside for later use in reassembly. Support the weight of the exhaust system and remove the two 8mm bolts and one 8mm nut securing the exhaust mounting bracket and exhaust assembly. Keep these fasteners for use later. Remove the stock exhaust system as one complete unit; this includes the stock exhaust bracket, headpipes and muffler, exhaust valve solenoid and cables.
5. The exhaust valve actuator solenoid must now be removed from the stock exhaust-mounting bracket. To perform this, loosen the two nuts securing each cable to the exhaust valve cable-mounting tab, Position A in Figure 1. Make enough slack in the cables so that the ends of the cable's threaded sheath may be disengaged from the end of the mounting tab. Now remove the two M6 hex head bolts securing the solenoid to the stock exhaust bracket. The stock exhaust mounting bracket, headpipes and muffler and exhaust valve solenoid cables will not be used anymore with the your new Cobra Exhaust System.

* Cobra® recommends you always wear a helmet while riding. Please never operate your motorcycle while under the influence of alcohol and/or drugs. Enjoy the new look of your motorcycle and please ride safely.

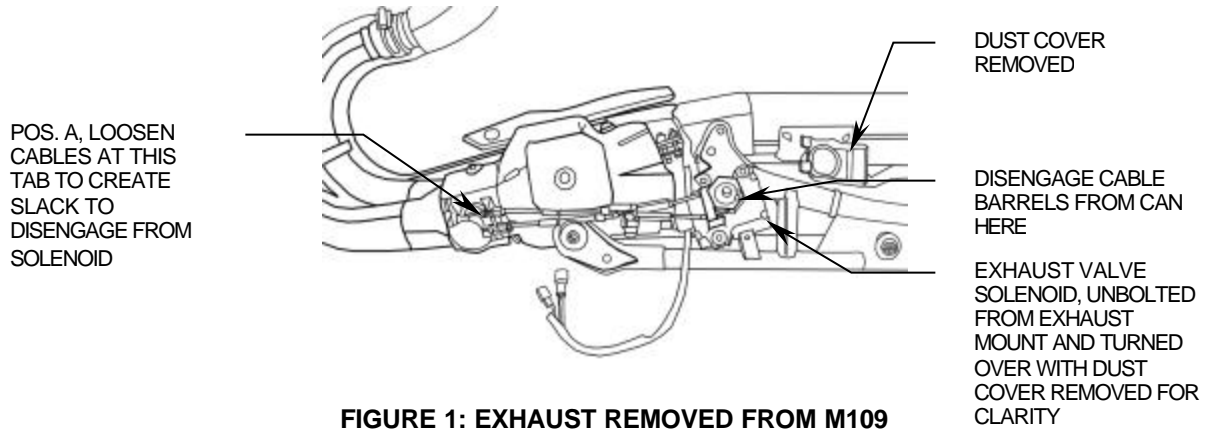
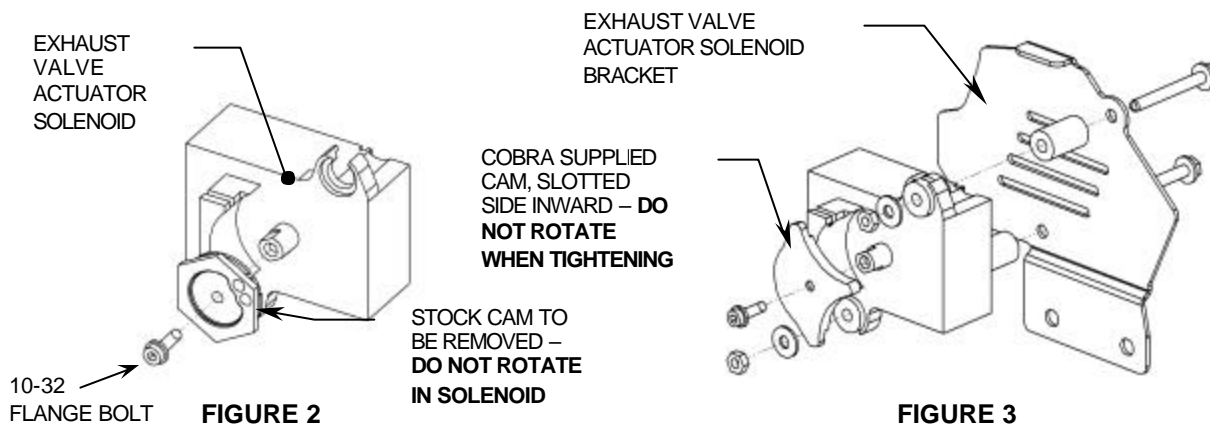

FIGURE 1: EXHAUST REMOVED FROM M109

6. Remove the dust cover from the solenoid to expose the rotating cam and cables. **DO NOT TRY TO ROTATE THE CAM RELATIVE TO THE ACTUATOR SOLENOID TO REMOVE THE CABLES; DOING SO MAY DAMAGE THE INTERNAL COMPONENTS OF THE SOLENOID.** To remove the cables from the cam, use the slack in the cables obtained in Step 5 to disengage the cable barrels from the cam, see Figure 1. **THE DUST COVER WILL NOT BE REINSTALLED.**
7. Now prepare the exhaust valve actuator solenoid for reuse. **SECURELY HOLD THE CAM TO PREVENT IT FROM ROTATING IN THE SOLENOID. WHILE PREVENTING THE CAM FROM ROTATING,** remove the 10 – 32 flange bolt securing it, see Figure 2. Replace the cam with the Cobra supplied cam, **BE SURE TO PREVENT THE CAM FROM ROTATING WHEN REINSTALLING THE BOLT, OTHERWISE DAMAGE MAY OCCUR TO THE SOLENOID,** see Figure 3. Torque to factory specifications.
8. After installing the cam, assemble the exhaust valve solenoid with the supplied Cobra parts as shown in Figure 3. Insert the two supplied M6 x 50 mm bolts through the supplied exhaust valve actuator bracket, aluminum spacers, solenoid, supplied flat washers, and supplied M6 lock nut. Once the assembly is complete and bolts are tightened set aside for later installation.
9. Loosen the right footpeg assembly and move it out of the way to help ease exhaust installation.



10. Install the exhaust mounting bracket onto the existing stud in the frame member; see Figure 4. Install the stock 8 mm nut and two stock 8 mm flange bolts into the exhaust bracket, tighten to factory specifications. Mate the preassembled exhaust valve solenoid and bracket to the inside of the exhaust mounting bracket using two 5/16" flange bolts inserted from the outside and two 5/16" washers and nuts from the inside, see Figure 4. Reconnect the black 3-prong connector and white 2-prong connector to the exhaust valve solenoid. Tighten to proper torque specs.
11. Install the front and rear headpipes onto the motorcycle using the supplied Cobra flanges and stock socket head bolts. **DO NOT TIGHTEN.**
12. Remove the muffler assembly from the box and slide two supplied 27 - 61MSC clamps onto the muffler inlets. The clamps should be orientated as shown in Figure 4. Slide the muffler onto the headpipes by tapping the headpipes with your hand as you push the muffler forward making sure the muffler slides as far forward as possible. Secure the muffler to the exhaust mounting bracket using the supplied 5/16"-18 bolts but **DO NOT TIGHTEN.**
13. Check all alignments and clearances then tighten the following in order, muffler assembly to the exhaust mounting bracket, headpipe flanges to the motor (slowly tighten opposing bolts) and finally the muffler clamps. (NOTE: If the muffler clamps are slid past the slots, the clamps will not tighten properly.)
14. Reinstall the steel chrome cover to the frame using the existing two M6 bolts from Step 2. Reinstall the small plastic fairing above the exhaust mounting bracket, and secure with M6 button head bolt. Reinstall the right side fairing removed in Step 1, and secure the fairing and steel chrome cover with the stock M6 button head bolt, see Figure 4. Reinstall the seat once all body panels have been secured in place.

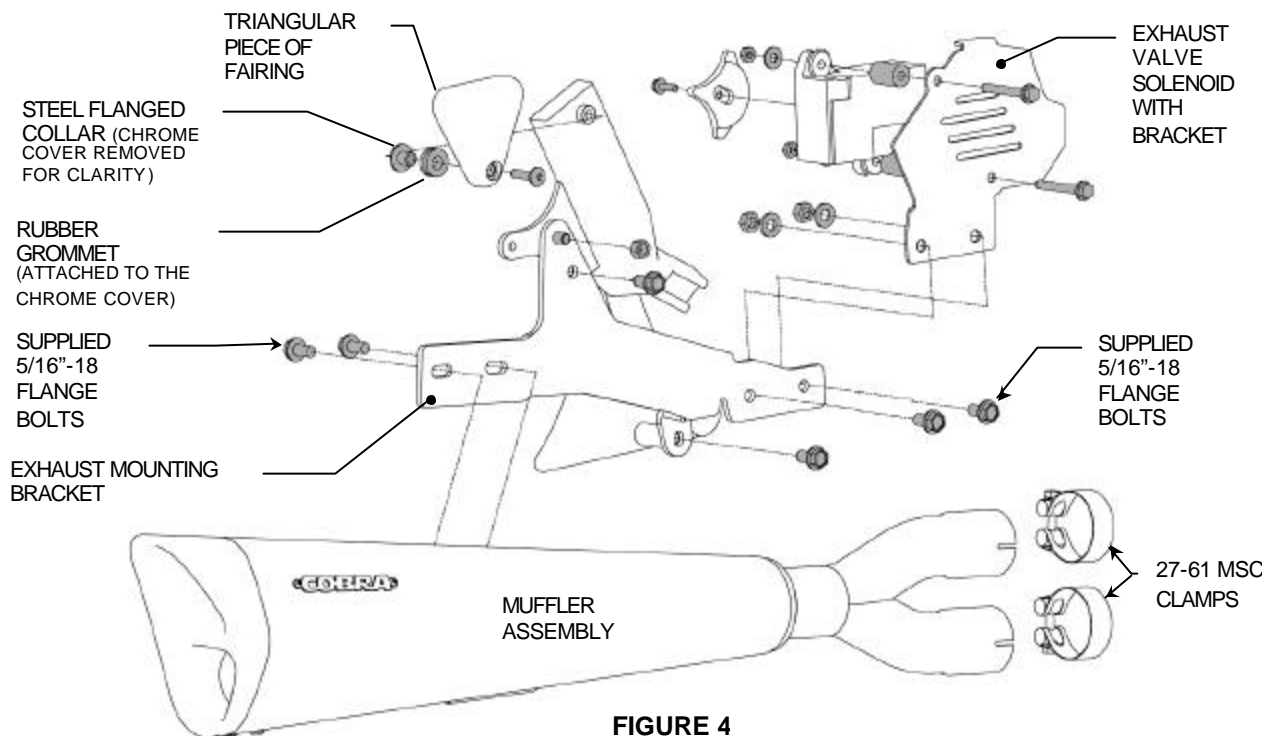
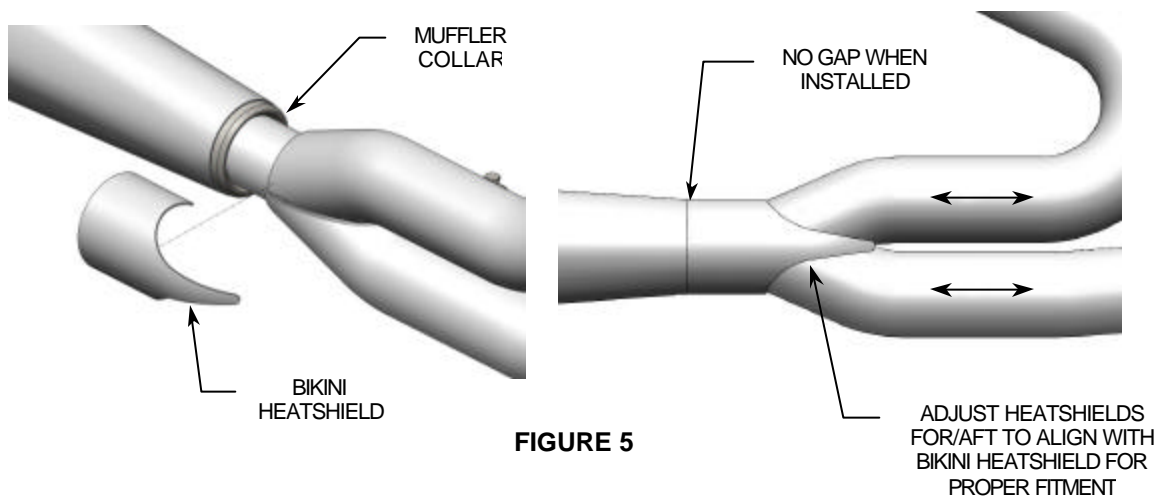

FIGURE 4

15. On the front and rear heatshields unscrew the HS-24 (smaller) hose clamps and feed the tail end of the clamp through the clips on the inside. The screw end of the hose clamps should be accessible for tightening but not visible when the heatshields are mounted to the pipes.
16. To install the front heatshield spread the hose clamps apart to make it easier to snap them over the headpipe. Snug the heatshield clamps but do not tighten. Install the rear heatshield the same way as the front heatshield.
17. Unscrew the HS-28 (larger) hose clamp and feed the tail end through the clip on the inside of the bikini heatshield. NOTE: orientate hose clamp so the hex head is towards the inside and facing the ground. Snap the bikini heatshield in place onto the muffler collar and over both headpipe heatshields. Adjust front and rear headpipe heatshields for and aft to align properly with bikini heatshield. There should be no gap between muffler and bikini heatshield when installed, Fig. 5.
18. Tighten the hose clamps on the headpipe heatshields followed by the hose clamp for the bikini heatshield. Reinstall the right footpeg assembly with the stock bolts and tighten to factory specs. Make sure all the components (brackets, headpipes, heatshields, and tips) have been tightened appropriately and cleaned before starting the motorcycle.



IMPORTANT: Cobra highly recommends using a Fi2000 Fuel Management System to help eliminate lean conditions and popping sounds. Cobra Part# 92-0845 for Fi2000 & 92-1845 for Fi2000R. For California models only use Part# 92-1845-50.

CLEANING

INSTRUCTIONS: To clean your black exhaust system use a liquid based soap detergent, such as dishwashing soap applied with a soft cloth and rinse with clean water. Note: Avoid abrasive cleaning methods such as granular or dry cleansers, simple green, scotch-brite or steel wool pads. Abrasives may breach the coating and shorten life.