



DELUXE PANACEA SMOKE TAILLIGHT 5401

DIRECT PLUG-IN: '96-UP FLST/C/N (EXCEPT '05-UP FLSTN), '02-UP FLSTF, '97-UP DRESSER/ROAD KING, '01 FXDX/T, ALL '02-UP DYNA (EXCEPT FXDWG), '02-'03 XL.

APPLICATIONS REQUIRING 8-PIN HARDWIRE ADAPTER, P/N 4832, SOLD SEPARATELY: '91-'95 FLSTC/N, '91-'96 DRESSER/ROAD KING.

APPLICATIONS REQUIRING 6-PIN TO 8-PIN ADAPTER, P/N 4831, SOLD SEPARATELY: '04-UP XL.

Note: Because of the "laydown" design, this light is not recommended for use on models equipped with "bobbed" rear fenders (FXST, FXDWG).

PARTS INCLUDED

- 1 Deluxe Panacea Taillight- Smoke Lens
- 1 Plug-in Panacea Master Control Assembly Kit, including:
 - 1 TSM Load Equalizer
 - 1 Control Module
 - 1 "Stock" Control Tab (for use on Full Coverage Fender)
 - 1 "Inverted" Control Tab (for use on Bobbed Fender)
 - 1 Accessory Light Plug-in Adapter for Twin Cams
 - 1 LED Fender Tip Replacement Light Chip
 - 1 Universal Foam Lens Gasket
 - 1 Adapter Kit, including:
 - 1 Evolution Style 1157 Base Connector
 - 1 Twin Cam Taillight Connector
 - 1 Dielectric Grease
 - 1 Installation Instructions

Please read and understand entire instructions before starting installation.

THANK YOU FOR CHOOSING KÜRYAKYN!

IN ORDER TO PROTECT YOU AND OTHERS FROM POSSIBLE INJURY AND/OR PROPERTY DAMAGE OR LOSS, PLEASE PAY CLOSE ATTENTION TO ALL INSTRUCTIONS, WARNINGS, CAUTIONS AND ATTENTION NOTES REGARDING THE USE AND CARE OF THIS PRODUCT.

WARNING! THIS INDICATION ALERTS YOU TO THE FACT THAT IGNORING THE CONTENTS DESCRIBED HEREIN CAN RESULT IN POTENTIAL DEATH OR SERIOUS INJURY.

CAUTION! This indication alerts you to the fact that ignoring the contents described herein can result in potential injury or material damage.

ATTENTION! This indication alerts you to the fact that ignoring the contents described herein may negatively affect product performance and functionality.

TOOLS SUGGESTED

Phillips screwdriver, small flat blade screwdriver.

STRICTLY OBSERVE THE FOLLOWING GUIDELINES IN ORDER TO USE THE PRODUCT PROPERLY AND AVOID POTENTIALLY DANGEROUS ACCIDENTS.

-cont.-

CUSTOMER SERVICE

877.370.3604 (toll free)

INSTALLATION QUESTIONS

techsupport@kuryakyn.com
or call 715.247.2983

LIMITED WARRANTY

Küryakyn warrants that any Küryakyn products sold hereunder, shall be free of defects in materials and workmanship for a period of one (1) year from the date of purchase by the consumer excepting the following provisions:

- Küryakyn shall have no obligation in the event the customer is unable to provide a receipt showing the date the customer purchased the product(s).
- The product must be properly installed, maintained and operated under normal conditions.
- Küryakyn makes no warranty, expressed or implied, with respect to any gold plated products.
- Küryakyn shall not be liable for any consequential and incidental damages, including labor and paint, resulting from failure of a Küryakyn product, failure to deliver, delay in delivery, delivery in non-conforming condition, or for any breach of contract or duty between Küryakyn and a customer.
- Küryakyn products are often intended for use in specific applications. Küryakyn makes no warranty if a Küryakyn product is used in applications other than intended.
- Küryakyn electrical products are warranted for one (1) year from the date of purchase by the consumer. Components of Küryakyn products containing L.E.D.s will be warranted for defects in materials and workmanship for 3 years from the date of purchase.
- Küryakyn makes no warranty of any kind in regard to other manufacturer's products distributed by Küryakyn. Küryakyn will pass on all warranties made by the manufacturer and where possible, will expedite the claim on behalf of the customer, but ultimately, responsibility for disposition of the warranty claim lies with the manufacturer.

ABOUT OUR CATALOG

You'll find all our innovations for H-D, GL and Metric Cruisers in our annual catalogs. Order online today—select the "CATALOGS" icon. Each Küryakyn® product comes with a Proof-of-Purchase good for a complimentary catalog. Details in packaging.

Be sure to ask your local dealer about other Küryakyn® products, the motorcycle parts and accessories designed for riders by riders.

©2005 Küryakyn USA® All Rights reserved.



NOTES

For the complete Panacea set (multi-function taillights and turn signals), the following turn signal inserts must be ordered separately. No other turn signals will provide multi-function (run, turn, brake) operation with the Panacea system.

- P/N 4967 or 4830 – Flat 3 1/4" "Pancake" Style (FLT, FLST, etc.)
- P/N 4835 or 4949 – "Deuce" Type Bullet

ATTENTION! This product is only compatible with motorcycles that have stock wiring configurations. Before attempting to install this product verify the following conditions:

- If the rear turn signals have been replaced with dual circuit turn signal assemblies, the stock single circuit assemblies must be reinstalled and all wiring returned to its original configuration.
- If additional lights have been added to the rear of the motorcycle they must either be connected to the motorcycle accessory circuit, spliced into the stock wiring harness upstream of the input side of the control module, or connected to the accessory plug supplied with this kit.
- All trailer wiring connections must be spliced into the stock wiring harness upstream of the input side of the control module.

PROCEDURE

INSTALL THE NEW TAILLIGHT

STEP 1 Remove the taillight lens; save the stock fasteners.

For Twin Cam and XL Models: Remove the stock taillight lens assembly and unplug it from the fender mounted taillight base.

For Evolution Models: Remove the taillight lens and unplug the bulb.

STEP 2 Install the correct taillight adapter for your bike. Apply a dab of dielectric grease to the adapter pins before connecting.

For Twin Cam Models: The "Amp" style adapter plugs into the taillight base in the same manner as the stock taillight; the adapter is keyed to fit only one way, see [PIC. 1](#).

For Evolution Models: The adapter installs like an 1157 light bulb; push the adapter in and turn it clockwise.

STEP 3 Clean the inside of the taillight base in the area of the gasket; dirt and other contaminants will prevent the gasket from adhering to the base. Remove the paper backing from the self-adhesive gasket and apply the gasket to the taillight base on the fender. The extra flap in the gasket is designed to seal the wire opening in the taillight base on Twin Cam and XL Models. If you normally drive in wet weather, you may want to seal the wire opening with silicone or electrical tape for extra protection.

ATTENTION! Ensure the area of installation is free of grease, oil, dirt or other debris to ensure proper adhesion. Kuryakyn WILL NOT warranty any parts lost due to improper installation.

ATTENTION! The adhesive will not bond correctly if applied at temperatures less than 50° F. Do not attempt this installation in temperatures less than 50° F.

STEP 4 Plug the taillight into the adapter; be sure like colored wires are aligned. The small black plugs are usually a tight fit — some effort may be required to seat the taillight into the adapter.

For Twin Cam and XL Models only: The adapter has an extra wiring harness coming from the taillight connector, see [PIC. 2](#). Use this extra harness to power an accessory such as a separate license plate light or any rear end lighting that is not original equipment. Wire functions are labeled to aid in making the correct connections. If you do not have accessory lighting, remove the pigtail from the connector to avoid a possible short circuit.

Kuryakyn®

PIC. 1



PIC. 2

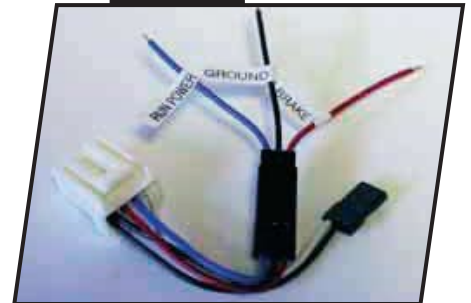

PIC. 3

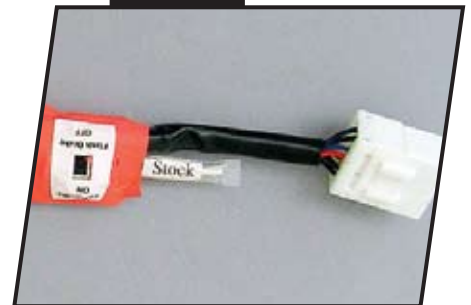

PIC. 4



PAGE

2

-cont.-

DELUXE PANACEA SMOKE TAILLIGHT

INSTALLATION

STEP 5 Install the Panacea taillight onto the taillight base using the stock fasteners. Set Up and Install the Panacea Control Module.

STEP 6 Verify the "stock" tab is installed in the end of the control module. See [PIC. 3](#).

NOTE: Installation of the Panacea taillight on models with "bobbed" fenders is possible, but not recommended, as the lens optics is not designed to be mounted upside-down. If you choose to disregard this recommendation and mount the taillight on a "bobbed" fender, be sure to replace the stock tab with the inverted tab. Be sure the ignition is "Off" before removing and replacing the tabs.

STEP 7 With the ignition "Off", set the selector switch on the control module for your particular turn signal application. A small, flat blade screwdriver works well to set the selector switch. See [PIC. 4](#).

For complete Panacea systems, using Panacea turn signal inserts: Set the selector switch on the module to the "Panacea" position.

For stock or any other single filament turn signals: Set the selector switch on the control module to the "Stock OEM" position.

STEP 8 With the ignition "Off", set the brake mode switch to your preferred mode. "Flash Brake on" mode pulses the brake lights several times before steady bright illumination when the brake is applied. "Flash Brake off" illuminates the brake in steady bright when the brake is applied.

STEP 9 Verify the supplied load equalizer is plugged into the 3-pin connector at the end of the control module.

FOR MODELS WITH OPTIONAL FRONT LED TURN SIGNALS:

An additional load equalizer must be used; attach the equalizer to the second connector on the control module. See [FIG. 1](#).

FOR INTERNATIONAL WIRING MODELS ONLY:

The control module must be modified for proper operation. The position of the blue and orange wires must be reversed on both the input and output plugs; consult a trained H-D technician.

CAUTION! Do not secure the load equalizer to the control module! Excess heat from the load equalizer could damage the control module.

CAUTION! Always install the load equalizer upstream of any existing aftermarket multifunction control modules. Do not install a load equalizer between a module and the turn signals as this will overload the module. Overloading will damage the module and create a fire hazard!

CAUTION! Load equalizers generate heat when in use. Avoid using the turn signals for an extended period of time, otherwise the load equalizer will overheat. Never operate the four-way flashers unless you first remove the load equalizer. Overheating damages the load equalizer causing loss of turn signal operation and could create a fire hazard!

STEP 10 Locate the main wiring harness going to the rear fender; the harness is located either under the seat or behind the side cover. Separate the harness at the main connector plug and install the control module inline. The connectors are keyed to only fit one way; be sure the connectors are fully seated for good electrical contact. See [PIC. 5](#).

FIG. 1

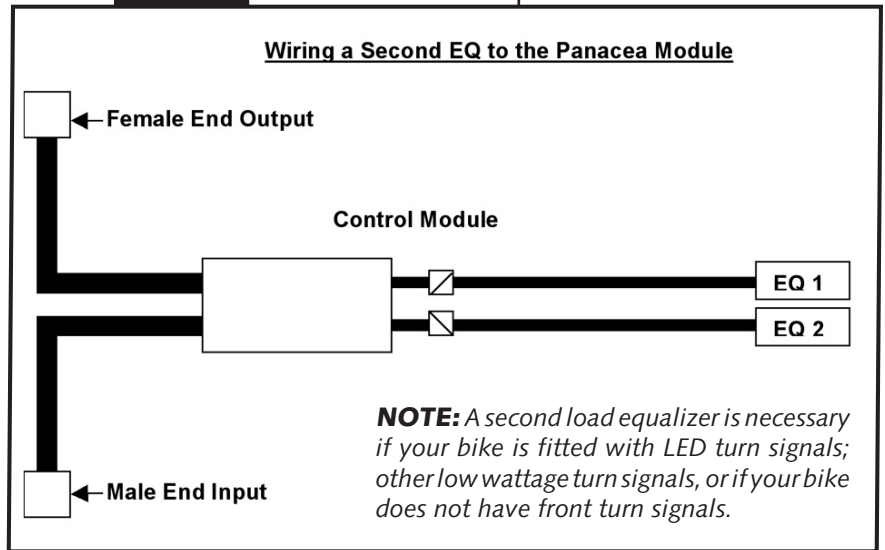

PIC. 5



PIC. 6

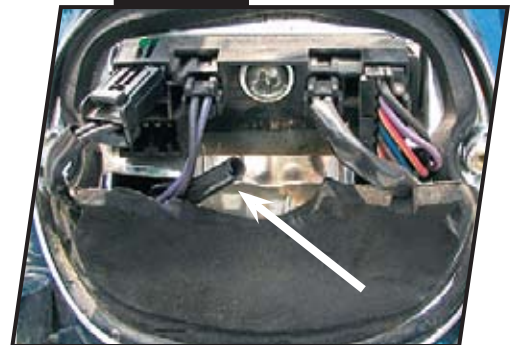

STEP 11 Use nylon cable ties or twist ties to secure the load equalizer tightly to either a frame rail or other metal surface—this will act as a heat sink to help cool the load equalizer when the turn signals are activated.

STEP 12 For Models with a rear fender tip light: Replace the incandescent bulb with the supplied LED light chip to ensure proper taillight operation. If the LED does not illuminate after installation, remove the chip, reverse its position and reinstall.

STEP 13 For Models with Panacea multi-function turn signals only: Remove the stock turn signal lens and bulb. Push the new connector into the socket and twist clockwise to secure. Install the LED lens with the stock screws.

STEP 14 For optional license plate light: Locate the power wire (black) in the connector for the accessory lights; mark the wire for reference. See [PIC. 6](#). Cut the connector off the stock wiring harness. Connect the power run wire (blue) to the accessory connector power wire you marked previously. Connect the ground wire (black) to the accessory connector ground wire. See [PIC. 7](#). Verify the connections are secure.

PIC. 7

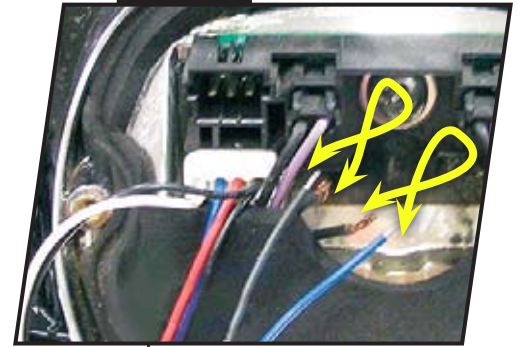

TEST LIGHTS FOR PROPER OPERATION

ATTENTION! Test the lights with the engine running.

STEP 15 Verify the taillight illuminates in running mode.

STEP 16 Verify the brake light flashes or illuminates in bright stop mode, depending on your brake mode selection, when either brake is applied.

STEP 17 Verify the correct amber chevrons in the taillight illuminate when the turn signals are activated.

BASIC TROUBLESHOOTING

Error	Solution
Directional arrows flash opposite of the turn signal lights.	Incorrect tab (either inverted or stock) installed in the control module. Refer to Step 6.
Turn signals operate but taillight either does not operate or operates erratically.	Install LED fender tip light. Refer to Step 12. Verify any rear accessory lighting is connected to the supplied adapter or spliced upstream of the control module. Refer to Step 4. For '05-up Screamin' Eagle or '06-up FLHX, it may be necessary to wire the license plate light to the adapter in the taillight. Refer to Step 4. Verify there are no H-D or aftermarket modules installed between the Panacea control module and the rear lights; remove any modules that are present.
Turn signals and arrows illuminate but do not flash.	Insufficient load; connect the load equalizer to the control module.
"Key" symbol light on dash remains illuminated; turn signal operation is normal.	This is a false alarm caused by an incompatibility between the H-D security system and the load equalizer. Operation of the alarm system is NOT affected in any way; however, if you find the "Key" light distracting, order a replacement load equalizer, Kuryakyn P/N 4857, to correct the problem.
Brake function does not illuminate when "Flash Brake off" is selected on the control module	You may have original style Panacea turn signals or taillights. Contact Tech Support for assistance, 1-715-247-2983 or techsupport@kuryakyn.com.