



Custom Dynamics Angel Eyes Wiring Kit

Custom Dynamics
Wake Forest, NC 27587
919-554-0949
www.customdynamics.com



Contents

- 1 Weather Proof Push Button Switch with Boot
- 1 Weather proof fuse holder
- 3 Amp ATC fuse
- 1' Black wire, 18 AWG
- 1' Red wire, 18 AWG
- 10 Tie wraps
- 2 Heat Shrinkable insulated terminals
- 6 Blue butt connector (heat shrinkable)
- 1" 3M Double Sided Tape
- 6' 22 gauge wire
- Optional: 6 Function Remote Control Unit

Tools Needed

- Screwdriver (flat and Philips)
- Wire Cutters
- Wire Strippers
- Wire Crimpers
- Heat gun or blow dryer
- Open End Wrenches
- Razor Blade Cutting Tool

Disclaimer: Custom Dynamics LLC assumes no liability of any kind as a result of conversions or additions to your vehicle.



Custom Dynamics Angel Eyes Wiring Kit

Custom Dynamics
Wake Forest, NC 27587
919-554-0949
www.customdynamics.com



1. Always wear appropriate safety gear including safety glasses when soldering or performing any electrical work. It is highly recommended that safety glasses be worn throughout this installation process. Temperature of bike must be at least 60 degrees F. for tape to properly cure. Read all directions before starting project.
2. Turn fuel supply valve to off position before starting. Be sure bike is on level surface and secure and cool.
3. **Important:** Disconnect negative battery cable from battery; refer to owner's manual. Failure do to so may result in electrical shock, injury, or fire. Secure negative battery cable away from positive side of battery and all other positive voltage sources on bike.
4. Follow manufacture instructions to mount Angle Eyes into headlights, once the angel eyes have been installed follow these instructions to wire the angel eyes.
5. Select appropriate mounting location for push button switch. Be sure mounting location is clean, use rubbing alcohol to clean surface if necessary. Place 3M tape on switch and mount switch on bike, place waterproof boot on switch. (Remote Control can be substituted for switch)
6. Following Block Diagram on Page 3 of instructions:
7. Join all black wires from Angel Eyes to piece of 22 AWG black wire (supplied) using the supplied butt connector. Crimp wires in connector.
8. Take remaining end of 22 AWG black wire and connect to 18 AWG Black wire with butt connector and crimp. Connect remaining end of black 18 AWG to frame ground on bike using terminal connector and crimp.
9. Join all red wires from Angel Eyes to a new butt connector. Crimp wires in connector. Connect one end of Red 22AWG into open end of butt connector, crimp wire.
10. Connect one end of push button switch to 22 AWG Red with butt connector. Crimp wires in butt connector..
11. Connect remaining end of push button switch to one end of fuse holder with a butt connector, insert wire and crimp.
12. Connect remaining end of fuse holder wire to 18 AWG red with a butt connector, crimp.
13. Place remaining terminal connector other end of 18 AWG Red, crimp wire in terminal connector.
14. Connect spade terminal to Positive (+) side of battery. Take necessary precautions when making connection and refer to bike's owner's manual. DO NOT allow any tools to touch both positive (+) side of battery and any metal surface on bike as it will cause a short which could result in serious injury and damage to the battery or other electrical circuits.
15. Secure any remaining wires with tie wraps.
16. Heat heat shrink connectors with heat gun or blow dryer until it shrinks down around wires.
17. Reconnect Negative Battery terminal to negative side of battery taking necessary precautions not to touch positive side of battery or any positive cable.
18. Place fuse in fuse holder and replace cover.
19. Turn on switch and check operation of all lights. Allow double-sided tape to bond for 72 hours before exposing to water

Optional: Instead of using butt connectors, joints can be soldered together and covered with supplied 3M Heat Shrink Tubing.

Disclaimer: Custom Dynamics LLC assumes no liability of any kind as a result of conversions or additions to your vehicle.



Custom Dynamics Angel Eyes Wiring Kit

Custom Dynamics
Wake Forest, NC 27587
919-554-0949
www.customdynamics.com



Block Diagram

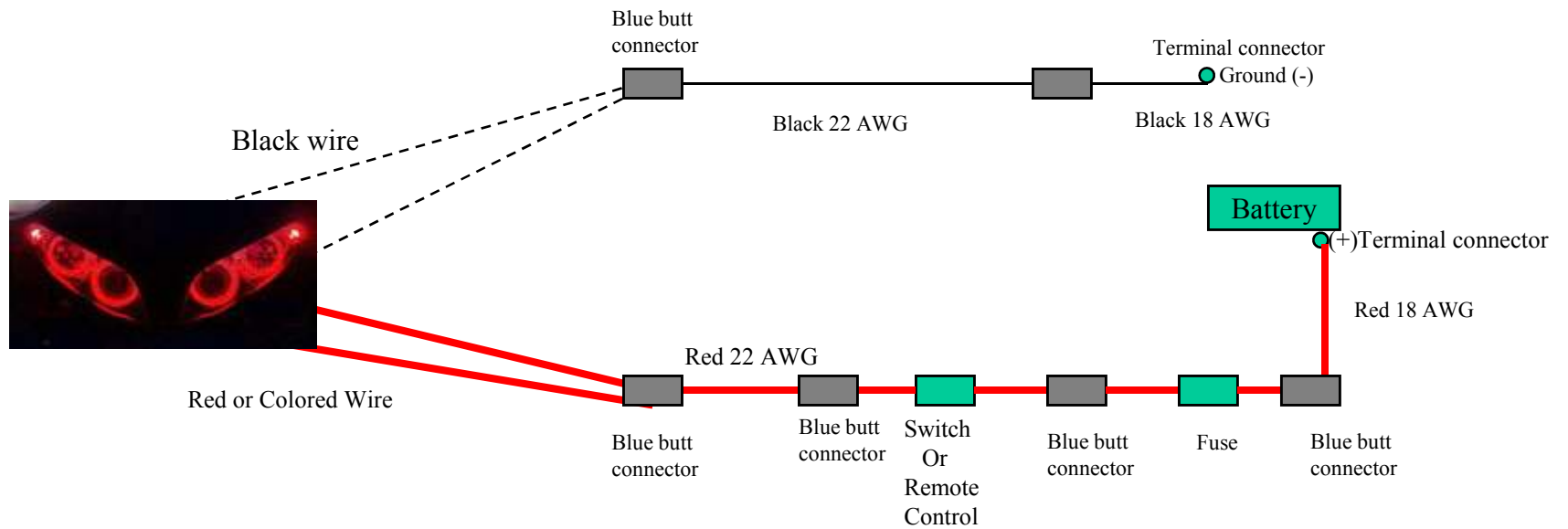

Disclaimer: Custom Dynamics LLC assumes no liability of any kind as a result of conversions or additions to your vehicle.