





# CONDOR PIT-STOP / TRAILER-STOP USER INSTRUCTION MANUAL

## **STOP! WARNING: READ THIS FIRST!**

First Read and Understand the Instruction manual and product labels for important safety, set-up and troubleshooting information. If you have problems setting up or using the Condor™ Pit-Stop, contact customer service @ 1-630-497-1962 or contact us via e-mail @ [www.condor-lift.com](http://www.condor-lift.com). Condor™ Pit-Stop is not intended for use by children.

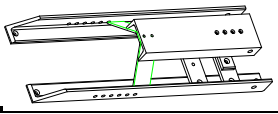
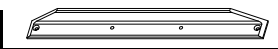
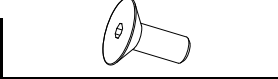
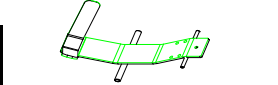
**Assembly Instructions:** Remove all parts from shipping box. Check the parts below to make sure you have all the parts needed to assemble your Condor™ Pit-Stop before beginning. In the unlikely event that you find a part damaged or missing, please call customer service @ #630-497-1962.

### **Condor Pit-Stop Parts Packing list:**

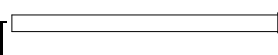
PICTURES OF PARTS	KEY	QUANTITY	PART DESCRIPTION
	A	1	Condor Main Unit
	B	1	Condor Base Back
	C	2	5/16-18 X 3/4 SS Flat head socket cap screw
	D	1	Condor Cradle
	E	1	3/8 X 10" Cradle pin with ring
	F	1	1/2 X 10" Front Stop pin with ring
	G	1	Hair Cotter 6 for 3/8X10" pin
	H	1	Hair Cotter 8 for 1/2 X10" pin
	I	1	Velcro Strap

### **Assembly Illustration:**

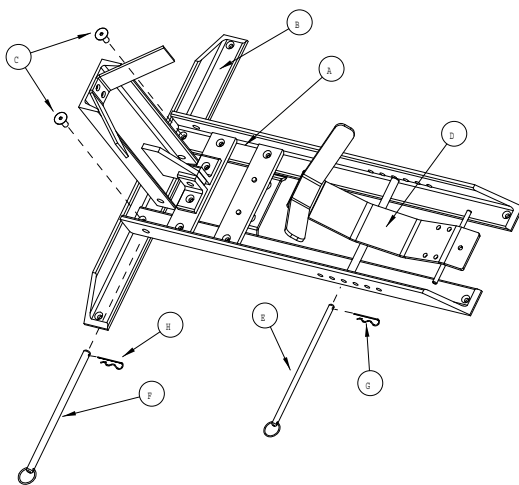

Step1: Using parts C, attach the Base Back to the Main Unit. (3/16 allen wrench required, torque between 16 - 18 ft-lbs)

Step2: Swing into position the front stop containing the CONDOR logo.

Step3: Place Pin F through Main Unit and front stop bracket. The pin may be tight at first use, push it through using light force and twisting it in. (Attach Hair Pin Cotter H once the pin has passed all the way through)

Step4: Place cradle as shown in the desired setting and insert Pin E through Main unit and cradle pipe. (Attach Hair Pin Cotter G once the pin has passed all the way through)

Warning: Only use unit when properly assembled.

**User Instructions:**

Confirm that the cradle is set in the optimized position setting for the entering tire and wheel. Adjustment of cradle is crucial for optimum retention. Optimum retention is achieved by trying different settings. Place unit in front of or behind motorcycle. Push or drive motorcycle centered into unit until the cradle of the Pit-Stop has fully engaged the wheel. Once the wheel is cradled, proceed to push further into the Pit-Stop until the wheel has engaged the front stop. If the optimum vertical support is achieved, the motorcycle will hold itself upright. If optimum retention is not achieved try different cradle settings. As an extra precaution, use the Velcro strap to strap the cradled wheel to the front stop. Always strap Velcro through the wheel and around the front stop below the upper front stop flange. For more information on use, refer to [www.condor-lift.com](http://www.condor-lift.com)

**Caution:** Always make sure that all fasteners are tight and all pins are in place prior to use. Understand the limitations of this product and do not exceed these limitations. Technical Components Development & Design is not responsible for any damage incurred by exceeding this product's limitations in structure and/or functionality.

**One Year Limited Warranty:**

This Condor™ Pit-Stop product warranty extends to the original consumer purchaser of the product. All illustrations and specifications contained in this manual are based on the latest product information available at the time of printing. Technical Components Development & Design, Inc. reserves the right to make changes at any time, without notice, in color, materials, equipment, options, specifications and models. Models may be shown with optional equipment. Further information may be obtained by contacting Technical Components Development & Design, Inc. @ #630-497-1962.

**Warranty Duration:**

This product is warranted to the original consumer purchase for a period of one (1) Year from original purchase date.

**What is not covered:**

Our warranty for your product will not cover abnormal wear of parts, damage resulting from negligent use or misuse of the product, use contrary to operating instructions, or disassembly, repair or alteration by any person other than an authorized service station. We shall not be liable for any incidental or consequential damages for breach of by express or implied warranty on your product.

**How your state's law may apply:**

Some states do not allow limitations on how long any implied warranty lasts or the exclusion or limitation of incidental or consequential damages. So the above limitation may not apply to you. This warranty gives you specific legal rights, and you may also have other rights, which may vary from state to state.

Thank you for purchasing the Condor Pit-Stop/Trailer-Stop.

Condor™ is a trademark of Technical Components Development & Design, Inc.

The Condor Pit-Stop / Trailer-Stop is US & International Patent Pending.

356 South Ave.

Sycamore, IL 60178

Phone: (815) 899-2912

Fax: (815) 895-6704

WebSite: [www.tcdevelopmentdesign.com](http://www.tcdevelopmentdesign.com)

