

BackOFF-Wig Wag™

Installation Instructions

Mode One Installation for - Wig Wag & Repeating Pattern:

- Before you begin...make sure your brake lights are working properly!
- Locate "brake light wires" (can usually be located under seat).
- Cut and splice Module into brake light wires (as shown in the schematic below). Secure "Red Wire" from Module to wire leading from "Brake Light Switch". Secure "Left" and "Right" wires leading to the Left and Right brake lights.
- Connect "Black Wire" to Ground.
- Secure BLSM-Wig Wag Module with included double-sided adhesive tape.

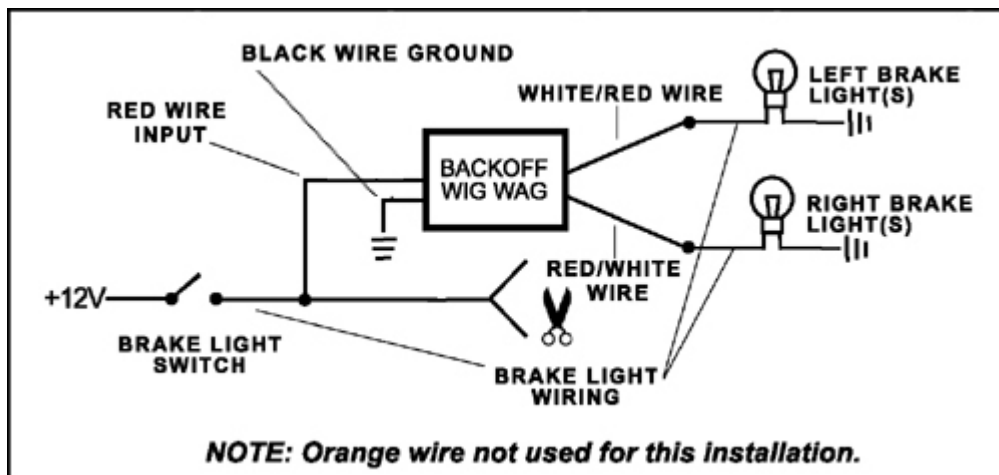

Mode Two Installation for - Wig Wag & Steady On:

- Before you begin...make sure your brake lights are working properly!
- Locate "brake light wires" (can usually be located under seat).
- Cut and splice Module into brake light wires (as shown in the schematic below). Secure "Orange Wire" from Module to wire leading from "Brake Light Switch". Secure "Left" and "Right" wires leading to the Left and Right brake lights.
- Connect "Black Wire" to Ground.

- Secure BLSM-Wig Wag Module with included double-sided adhesive tape.

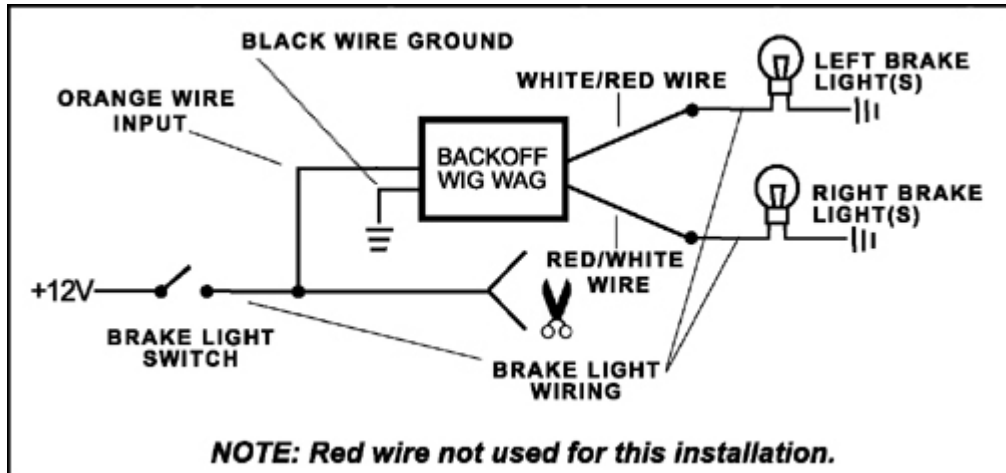

[Home](#) | [Search](#) | [Help](#) | [Contact](#) | [Cart & Checkout](#)

©2004 Signal Dynamics Corporation