



Custom Dynamics® Saddlebag LED Latch Lightz™ Installation Instructions

We thank you for purchasing the Custom Dynamics® Saddlebag LED Latch Lightz™. Our products utilize the latest technology and high quality components to ensure you the most reliable service. We offer one of the best warranty programs in the industry and we back our products with excellent customer support, if you have questions before or during installation of this product please call Custom Dynamics® at 1(800) 382-1388.

Part Numbers: CD-LATCH-BCM-R
CD-LATCH-BCM-S

Package Contents:

- Saddle Bag LED Latch Lightz™ (2)
- BCM Y Harness Adapter w/ Plugs (1)
- Quick disconnect Harness (2)
- 4" Tie Wraps (10)
- Tie Wrap Holder (8)
- Foam Strip (2)
- Rubber Grommet (2)
- Drilling Template (1)
- JAE Connector (2)

Fits: 2014-2024 Harley-Davidson® Ultra Limited (FLHTK) 2014-2023 Street Glide (FLHX), Street Glide Special (FLHXS), 2015-2023 Road Glide (FLTRX), Road Glide Special (FLTRXS), 2017-2024 Road King Special (FLHRXS), 2022-2023 CVO™ Road Glide Limited (FLTRKSE), 2020-2024 Road Glide Limited (FLTRK), 2014-2019 Electra Glide Ultra Classic (FLHTCU), 2015-2016 Ultra Classic Lo (FLHTCUL), 2016 CVO™ Road Glide Ultra (FLTRUSE), 2016-2019 Road Glide Ultra (FLTRU), 2015-2018 Ultra Limited Lo (FLHTKL) and 2016-2021 CVO™ Limited (FLHTKSE).

Functions as Run/Brake/Turn on 2014-2024 Harley-Davidson® Ultra Limited (FLHTK), 2014-2023 Street Glide (FLHX), Street Glide Special (FLHXS), 2015-2023 Road Glide (FLTRX), Road Glide Special (FLTRXS), 2017-2024 Road King Special (FLHRXS), 2014-2019 Ultra Classic (FLHTCU), Ultra Classic Lo (FLHTCUL), Ultra Limited Lo (FLHTKL), Road Glide Ultra (FLTRU), 2020-2024 Road Glide Limited (FLTRK), 2016 Road Glide Ultra CVO (FLTRUSE), 2022-2023 Road Glide Limited CVO (FLTRKSE) and 2016-2022 Limited CVO (FLHTKSE).

Functions as Run/Turn on 2014-2023 Harley-Davidson® Road King (FLHR), Street Glide ST (FLHXST), Street Glide CVO (FLHXSE), Road Glide ST (FLTRXST), Road Glide CVO (FLTRXSE), 2014 Road King CVO (FLHRSE), 2015 Road Glide Ultra CVO (FLTRUSE), 2014-2015 Ultra Limited CVO (FLHTKSE), 2014-2018 Electra Glide Police (FLHTP) and 2019-2022 Electra Glide Standard (FLHT).

The BCM can be serviced by a Harley Davidson™ Technician to have Run/Brake/Turn function. Custom Dynamics® SMART Triple Play® is a simple plug and play alternative option for Run/Brake/Turn function.

Refer to page 3 & 4 for diagrams on alternative functions and wiring.

Installation:

1. Secure motorcycle on level surface. Remove seat. Disconnect negative battery cable from the battery.
2. Locate and unplug the lighting connector to the rear fender.
3. Plug the provided BCM Y Harness Adapter, in-line, into the rear lighting harness and into the bike's main wiring harness.
4. Open saddle bag lid and remove any personal items from the saddle bag.
5. With the saddle bag open, disconnect the check strap from the lid of the saddlebag. Save the hardware for reassembly. The saddlebag lid will need to remain fully open to the outside of the saddlebag. Take protective measures so the saddlebag and/or lid are not damaged during the rest of the installation.
6. Remove the hinge cover from the hinge and locking mechanism.
7. With the hinge cover laying face down on a flat surface, place the hole templet on the back of the hinge cover and mark the hole location. See Photo 1
8. Carefully drill a 1/4" hole where you marked it in the previous step. Do not drill all the way through the reflector, you only want to drill through the hinge cover.
9. Use a small screwdriver and push the reflector out from the back side of the hinge cover where you drilled the hole. See Photo 2.
10. With the reflector removed, enlarge the hole you drilled in step 8 to 3/8". Clean any debris and adhesive from the area where the reflector was removed.
11. Wipe the reflector area down with denatured alcohol and let dry.



ATTENTION

Please read all Information below before Installation

Warning: Disconnect negative battery cable from battery; refer to owner's manual. Failure to do so may result in electrical shock, injury, or fire. Secure negative battery cable away from positive side of battery and all other positive voltage sources on vehicle.

Safety First: Always wear appropriate safety gear including safety glasses when performing any electrical work. It is highly recommended that safety glasses be worn throughout this installation process. Be sure vehicle is on level surface, secure and cool.

Important: This product is designed and intended for use as auxiliary lighting only. It is NOT intended to replace any original equipment lighting installed on the vehicle and should not be used for that purpose. This product must be wired so that it does not interfere with any original equipment lighting.

Important: Ambient install temperature must be 60 degrees F or higher. Allow 24 hours for tape to cure before washing or prolonged use of vehicle.

Note: The Y Harness Adapter must be plugged into the output (behind) any Smart Signal Stabilizer™/load equalizer or any brake strobe modules.

Note: The Y Harness Adapter must be plugged into the input (in front) of any run/brake/turn module.

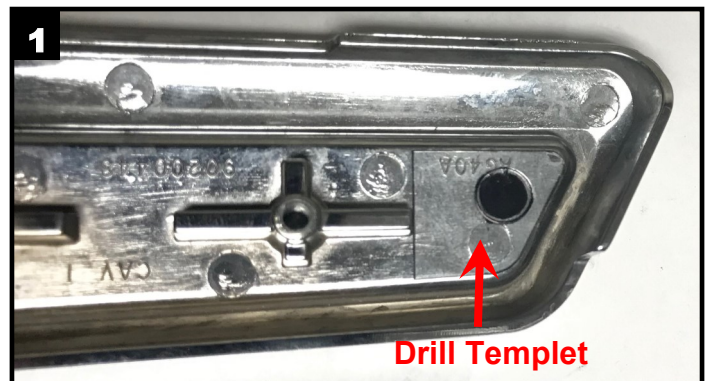

Questions? Email: info@CustomDynamics.com or Call us at: 1 (800) 382-1388 M-TH 8:30AM-5:30PM / FR 9:30AM-5:30PM EST

Installation Continued:

12. Route wire from Latch Lightz™ through the hole you drilled in the hinge cover. Remove the protective red film from the back of the Latch Lightz™. Align the Latch Lightz™ in the reflector area and press into place.
13. Reinstall the hinge cover on the saddle bag hinge.
14. Install the provided foam strip on the top outside lip of the saddle bag as shown in Photo 3.
15. Route wire from Latch Lightz™ over the foam pad and around to the front of the saddle bag towards the locking latch. Secure the wire to the inside of the saddlebag using the provided tie wrap holders and tie wraps as shown in Photo 4. Apply adhesive primer to mounting location of the tie wrap holder before pressing into place.
16. Remove saddlebags from the motorcycle. Transfer the saddle bags to a protected work area to prevent scratches.
17. Using a grease pencil, mark desired drill point for the Latch Lightz™ wire to exit the saddle bag. It is recommended the drill hole is located approximately 1" below the saddle bag latch as shown in Photo 5. Apply masking tape to the outside of the saddlebag at the marked drill point.
18. Using a 9/16 drill bit, drill a hole through the marked drill hole on each saddlebag. Drill from the outside of the saddlebag to the inside then remove masking tape. It is recommended to start with a smaller drill bit and work up to a 9/16 drill bit.
19. Install the provided rubber grommet into the hole you drilled in the previous step.
20. Route wire from each Latch Lightz™ through the rubber grommets and out the backside of the saddle bag.
21. Install the provided JAE connectors onto the pre-pinned wires from each Latch Lightz™ by pushing the pins into the connector ports according to Photo 6 (locking tab oriented at top of JAE connector):
 - Port 1 = Empty
 - Port 2 = Yellow
 - Port 3 = Black [-]
 - Port 4 = Brown or Purple
23. Pins should snap in place and not pull back out of connector when installed correctly.
24. Reinstall saddlebags and plug in the male JAE connectors from each Latch Lightz™ to the female JAE connectors (black) of the quick disconnect harness.
25. Plug the quick disconnect harness into the BCM Y Harness adapter.
26. Secure wires under the seat with tie wraps to secure wires from becoming cut, frayed, or pinched.
27. Reinstall motorcycle seat and test operation of all lighting before riding.

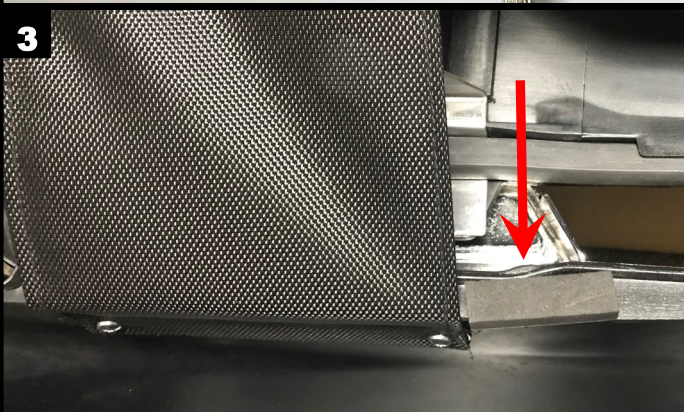
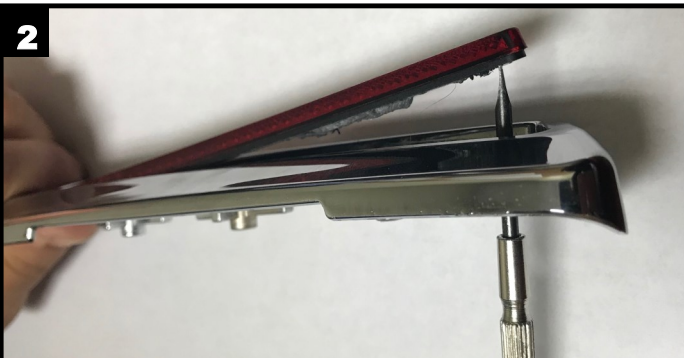

Installation Instructions - Page 3

Run-Brake Modification

For 2014 CVO™ Road King, 2015-2022 CVO™ Street Glide, 2018-2022 CVO™ Road Glide, 2014-2023 Road King® Standard, 2014-2015 Limited CVO™ & 2015 Road Glide Ultra CVO™

*Purple and Brown Wires going from the 3 Pin Connectors to the Y Harness must be cut and moved from the Purple and Brown to the Red Connections can easily be made using Posi-Tap™ connectors (Sold Separately)

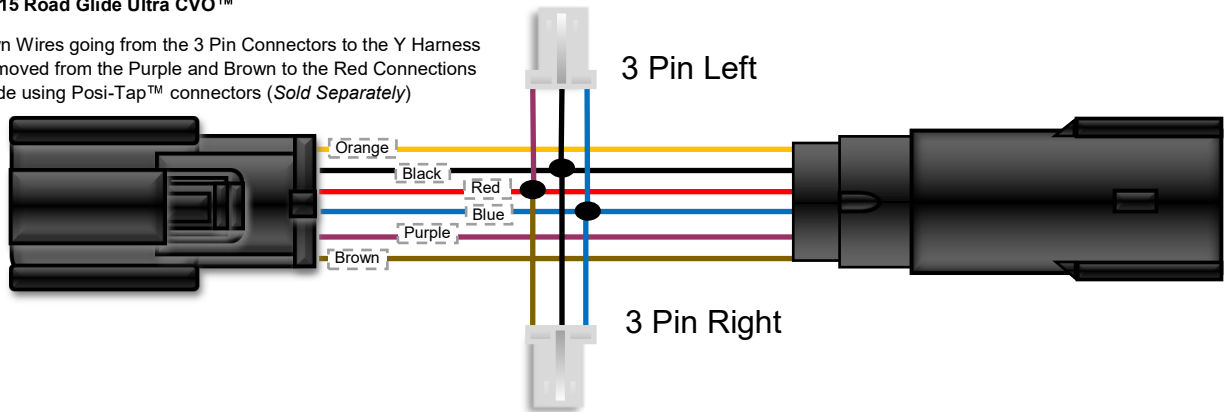

Run-Brake-Turn Modification

For 2014-2023 Road King® Standard, 2014-2015 Limited CVO™ & 2015 Road Glide Ultra CVO™ 2014 CVO™ Road King.

Plug-N-Play with SMART Triple Play® accessory plugs

*SMART Triple Play® with accessory plugs required. The provided BCM Y harness **will not** be used. The two 3 pin connectors that extend from the output side of the Smart Triple Play® module allow for plug and play installation. Simply plug in the left side (purple) and right side (brown) female connectors from the Smart Triple Play® to the corresponding male connectors on the product.

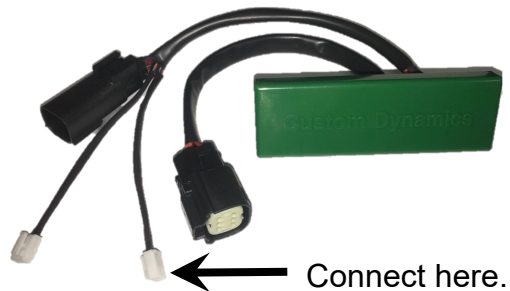
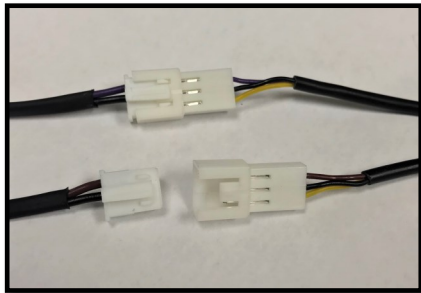

SMART Triple Play® without accessory plugs

*SMART Triple Play® without accessory plugs required. On the BCM Y Harness Adapter, the Blue wires going to both three pin connectors must be cut and capped off. BCM Y Harness Adapter must be installed on output side of SMART Triple Play®

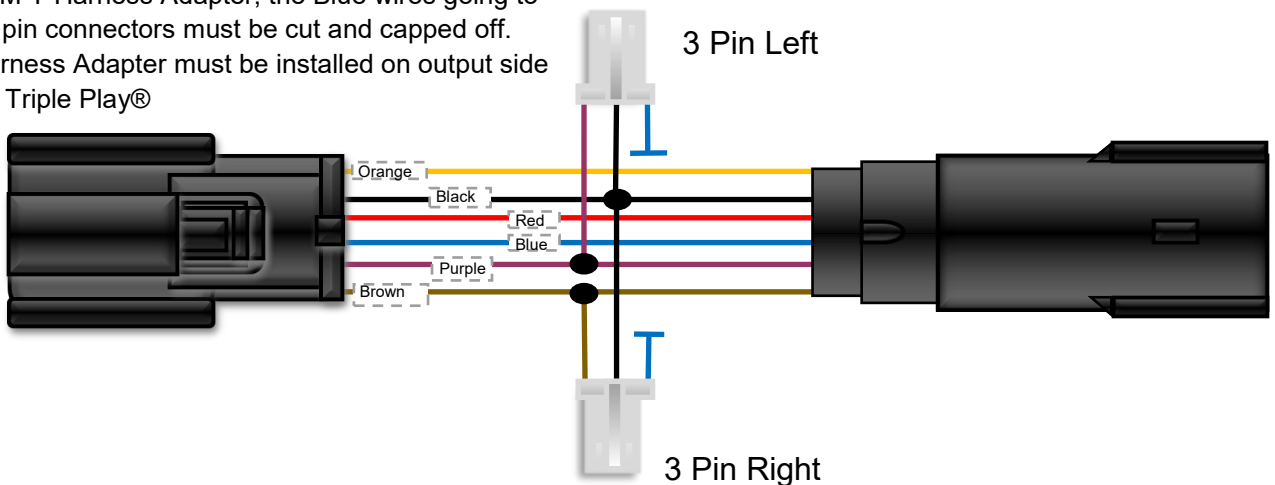

Installation Instructions - Page 4.

Run-Brake-Turn modification with GEN-SMART-TPU-14CVO

2014 CVO™ Road King, 2015-2022 CVO™ Street Glide & 2018-2022 CVO™ Road Glide

NOTE 1:

Cut and remove the 3 pin plug from each LED Latch Lightz™ light to expose the black, yellow, and brown (right side) or purple (left side) wires. Cap off the yellow wire from each LED Latch Lightz™. Connect the pig-tail output wires from the Smart Triple Play® using the supplied Posi-Lock™ connectors to the exposed black and brown (right side) or (left side) purple wires on the Custom Dynamics® LED Latch Lightz™

NOTE 2:

Cut the license plate light harness and connect the Blue and Black wires with the Posi-Lock™ installed on the Smart Triple Play® to side of the license plate harness going to the license plate light. Cap off the other side of the license plate harness wires with heat shrink and tuck it into factory conduit.

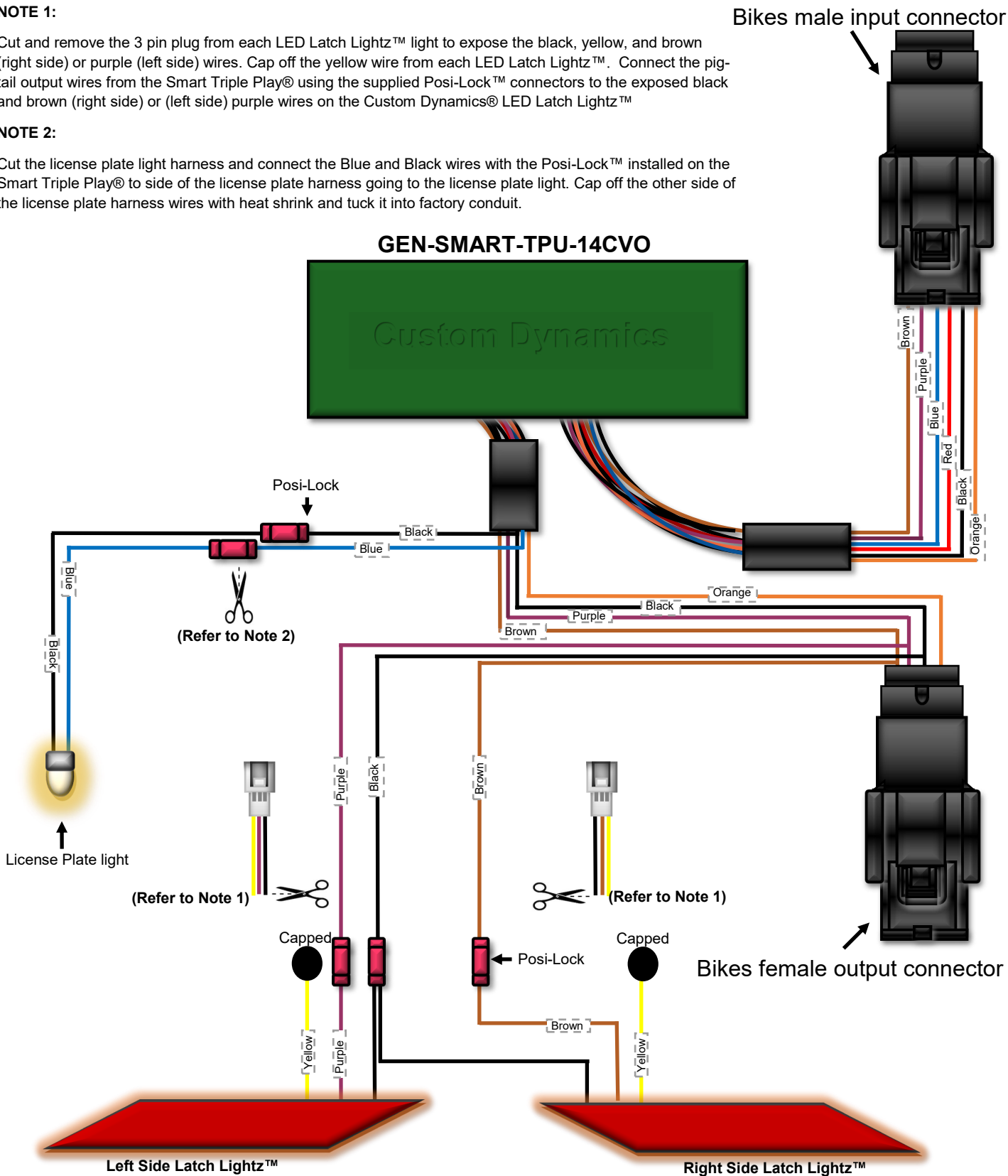

Questions? Email: info@CustomDynamics.com or Call us at: 1 (800) 382-1388 M-TH 8:30AM-5:30PM / FR 9:30AM-5:30PM EST

Package Contents



BCM Y Harness Adapter



Wire Ties



Tie Wrap Holders



Grommets

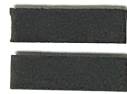

Foam Pads



Quick Disconnect Harness



Drill Templet



Quick Disconnect Harness



LED Latch Light



JAE Connectors



LED Latch Light