



## Custom Dynamics® Plug and Play Plasma Rod™ Adapter Installation Instructions

We thank you for purchasing the Custom Dynamics® Plug and Play Plasma Rod™ Adapter. Our products utilize the latest technology and high quality components to ensure you the most reliable service. We offer one of the best warranty programs in the industry and we back our products with excellent customer support, if you have

**Part Numbers:** PR-MPR-BCM

**Package Contents:**

- BCM Plasma Rod™ Adapter w/ Plugs (1)

**Fits:** Functions as **Run, Brake & Turn Signal** on 2014-2021 Harley-Davidson® Street Glide (FLHX), Street Glide Special (FLHXS), Road Glide (FLTRX), Road Glide Special (FLTRXS), Road Glide Limited (FLTRK), Road Glide Ultra (FLTRU), Ultra Classic (FLHTCU), Ultra Classic Low (FLHTCUL), Ultra Limited (FLHTK), Ultra Limited Low (FLHTKL), Road King Special (FLHRS), 2016 Road Glide Ultra CVO™ and 2016-2021 Ultra Limited CVO (FLHTKSE) with PR-PLUG-R Plug and Play Red Plasma Rods™ (Sold Separately).

Functions as **Run/Turn** on 2014-2021 Harley-Davidson® Road King® (FLHR), 2014 Road King® CVO™ (FLTRXSE), 2014-2021 Street Glide® CVO™ (FLHXSE), 2018-2021 Road Glide® CVO™ (FLTRXSE), 2015 Road Glide® Ultra CVO™ (FLTRUSE), 2014-2015 Ultra Limited CVO™, 2014-2018 Electra Glide® Police (FLHTP) and 2019-2021 Electra Glide® Standard (FLHT) with PR-PLUG-R Plug and Play Red Plasma Rods™ (Sold Separately).

\*Refer to page 2 & 3 for diagrams on alternative functions and wiring.\*



### Installation:

1. Secure motorcycle on level surface. Remove seat and disconnect negative battery cable from the battery.
2. Locate and unplug the rear lighting harness connector to the rear fender.
3. Plug the provided BCM Plasma Rod™ Adapter, in-line, into the rear lighting harness and into the bike's main wiring harness.
4. Connect the Plug and Play Plasma Rods™ (Sold Separately) to the installed BCM Plasma Rod™ Adapter. Connect Left Plasma Rod™ to the 3 pin connector of the BCM Plasma Rod™ Adapter with the Purple wire. Connect Right Plasma Rod™ to the 3 pin connector of the BCM Plasma Rod™ Adapter with the Brown wire.
5. Secure wires under the seat to prevent the wires from becoming cut, frayed, or pinched.
6. Reconnect the negative battery cable to the battery and reinstall the seat.
7. Test operation of all lighting before riding.



## ATTENTION

Please read all Information below before Installation

**Warning:** Disconnect negative battery cable from battery; refer to owner's manual. Failure to do so may result in electrical shock, injury, or fire. Secure negative battery cable away from positive side of battery and all other positive voltage sources on vehicle.

**Safety First:** Always wear appropriate safety gear including safety glasses when performing any electrical work. It is highly recommended that safety glasses be worn throughout this installation process. Be sure vehicle is on level surface, secure and cool.

**Important:** This product is designed and intended for use as auxiliary lighting only. It is NOT intended to replace any original equipment lighting installed on the vehicle and should not be used for that purpose. This product must be wired so that it does not interfere with any original equipment lighting.

**Note:** The BCM Plasma Rod™ Adapter must be plugged into the output (behind) any Smart Signal Stabilizer™/load equalizer or any brake strobe modules.

**Note:** Plasma Rods™ are designed to operate as **Run/Brake**. However, lights can be configured to operate as Run/Turn or Run/Brake/Turn. See page 2 & 3 for alternative configurations.

Questions? Call us at: 1 (800) 382-1388 M-TH 8:30AM-5:30PM / FR 9:30AM-

# Installation Instructions - Page 3

## Run-Brake Modification

For 2014 CVO™ Road King, 2015-2021 CVO™ Street Glide, 2018-2021 CVO™ Road Glide, 2014-2021 Road King® Standard, 2014-2015 Limited CVO™ & 2015 Road Glide Ultra CVO™

\*Purple and Brown Wires going from the 3 Pin Connectors to the BCM Plasma Rod™ Adapter must be cut and moved from the Purple and Brown to the Red Connections can easily be made using Posi-Tap™ connectors (Sold Separately)

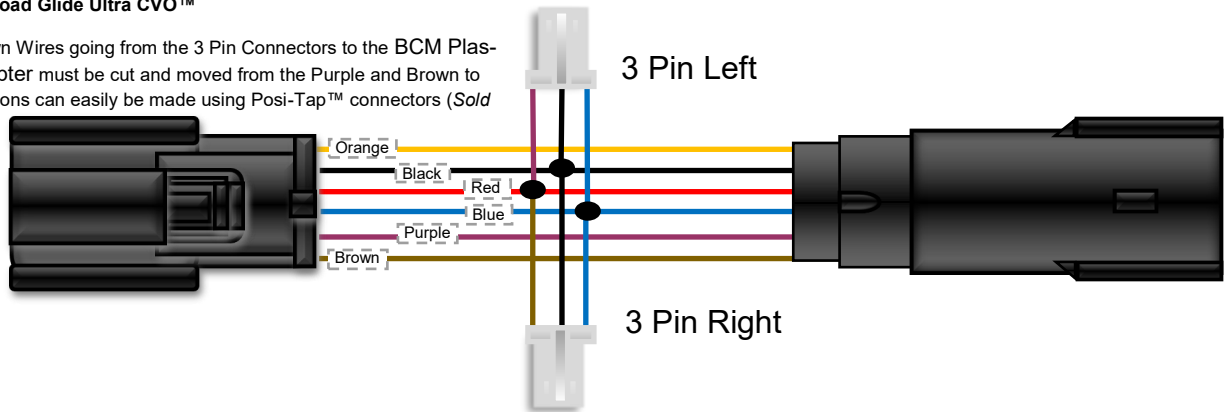

## Run-Brake-Turn Modification

For 2014-2021 Road King® Standard, 2014-2015 Limited CVO™ & 2015 Road Glide Ultra CVO™ .

### Plug-N-Play with SMART Triple Play® accessory plugs

\*SMART Triple Play® with accessory plugs required. The provided BCM Plasma Rod™ Adapter **will not** be used. The two 3 pin connectors that extend from the output side of the Smart Triple Play® module allow for plug and play installation. Simply plug in the left side (purple) and right side (brown) male connectors from the Smart Triple Play® to the corresponding female connectors on the product.

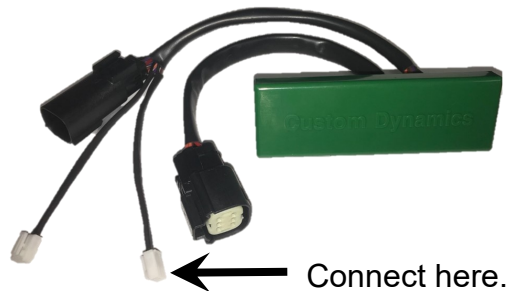
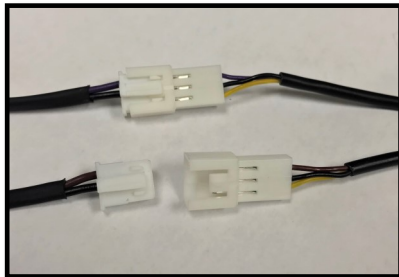

### SMART Triple Play® without accessory plugs

\*SMART Triple Play® without accessory plugs required. On the BCM Plasma Rod™ Adapter, the Blue wires going to both three pin connectors must be cut and capped off. BCM Y Harness Adapter must be installed on output side of SMART Triple Play®

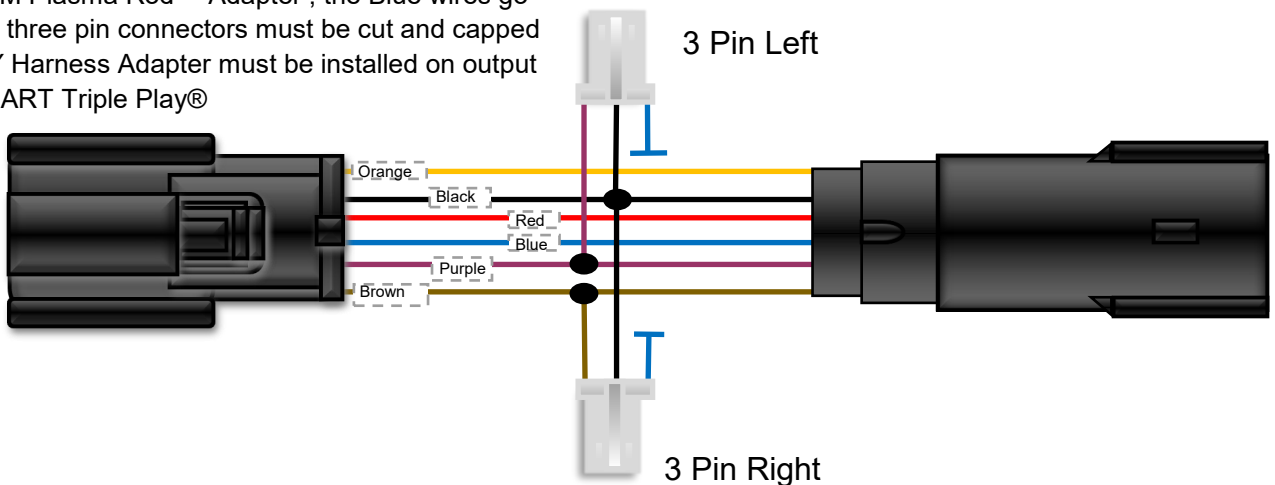

Questions? Call us at: 1 (800) 382-1388 M-TH 8:30AM-5:30PM / FR 9:30AM-5:30PM EST

## Installation Instructions - Page 3

### Run-Brake-Turn modification with GEN-SMART-TPU-14CVO

2014 CVO™ Road King, 2015-2021 CVO™ Street Glide & 2018-2021 CVO™ Road Glide

SMART Triple Play® (**GEN-SMART-TPU-14CVO**) required. On the BCM Plasma Rod™ Adapter, the Blue wires going to the two 3 pin connectors must be cut and capped off.

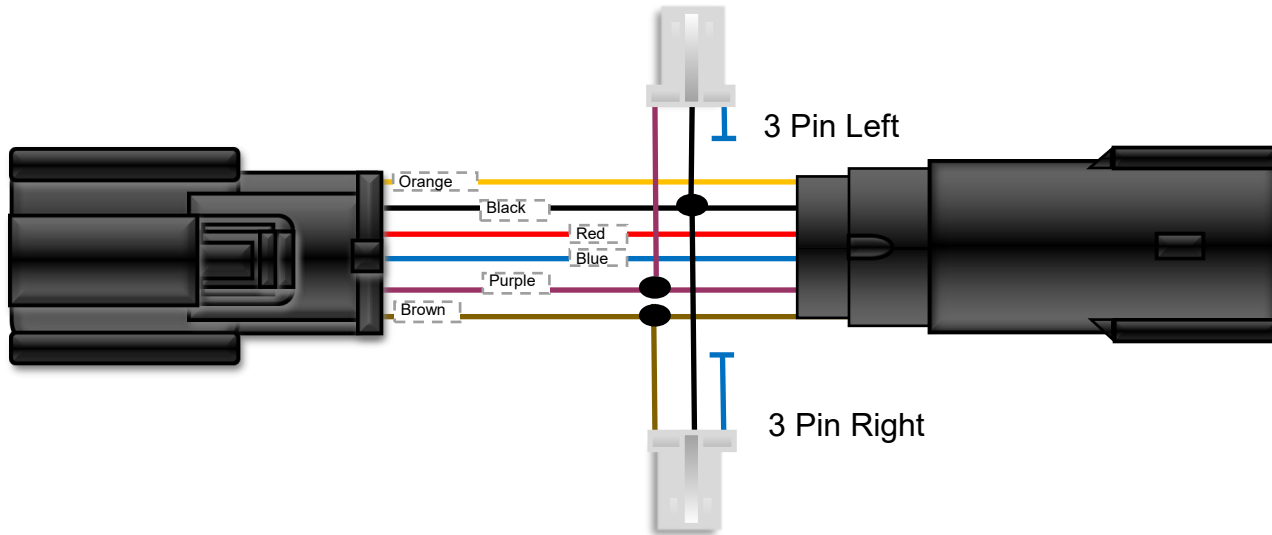

Questions? Call us at: 1 (800) 382-1388 M-TH 8:30AM-5:30PM / FR 9:30AM-5:30PM EST