



Custom Dynamics® 7" ProGLOW™ LED Headlamp Installation Instructions

We thank you for purchasing the Custom Dynamics® 7" ProGLOW™ LED headlamp! Our products utilize the latest technology and high quality components to ensure you the most reliable service. We offer one of the best warranty programs in the industry and we back our products with excellent customer support, if you have questions before or during installation of this product please call Custom Dynamics® at 1(800) 382-1388.

Part Number: PG-7-14-B PG-7-14-C

Package Contents:

- 7" ProGLOW™ LED Headlamp (1)
- H4-TOUR-ADAPTER (1)
- Instructions



Fits: . 2014-2023 Harley-Davidson® Street Glide (FLHX), Street Glide Special (FLHXS), Ultra Limited (FLHTK) & Tri Glide Ultra (FLHTCUTG). 2015-2023 Freewheeler (FLRT), 2017-2023 Road King Special (FLHRXS), 2014-2022 Road King (FLHR), 2022-2023 Street Glide ST (FLHXST), 2015-2022 CVO™ Street Glide (FLHXSE), 2019-2022 Electra Glide Standard (FLHT) & CVO™ Tri Glide (FLHTCUTGSE), 2014-2019 Electra Glide Ultra Classic (FLHTCU), 2015-2016 Ultra Classic Lo (FLHTCUL), 2015-2018 Ultra Limited Lo (FLHTKL), 2014-2021 CVO™ Limited (FLHTKSE), 2014 CVO™ Road King (FLHRSE) and 1984-2017 FL Softail models with OEM 7" headlight buckets.

Note: Requires ProGLOW™ Bluetooth Controller (sold separately) and ProGLOW™ App download for control of color changing halo.

Note: 2014-2022 Harley-Davidson® Road King (FLHR), 2017-2020 Road King Special (FLHRXS), and 2020-2023 Freewheeler (FLRT) require wiring adapter 2001-1264 (sold separately).

Fairing Installation:

1. Disconnect the vehicle battery negative [-] terminal.
2. Review detailed service manual for instructions on replacing factory headlamp.
3. Remove the factory headlamp trim ring, retaining ring and headlamp only.
4. Connect the 7" LED headlamp to the existing factory H4 plug.

Note: 2014-Current Street Glide, Electra Glide, Ultra and Tri Glide models (Including CVO™), 2014 Road King CVO™ and 2021-2023 Road King Special will need to use the included H4-TOUR-ADAPTER. If your headlamp's electrical harness connector does not match the flat 4 pin connector of the H4-TOUR-ADAPTER, follow your bike's harness back into the fairing until you find your bike's flat 4 pin connector.

5. Install the headlamp, retaining ring, and trim ring. Make sure no wire or any components of the harnesses can be pinched during installation and that they will not be exposed.
6. Connect the ProGLOW™ wiring harness to Channel 1 of the ProGLOW™ Bluetooth Controller. Note: If the Brake Signal Sync is turned on in the App, The Channel 1 Override will need to be turned ON as shown in Photo 1.
7. Re-connect vehicle battery negative [-] terminal.
8. Test high and low beam functions of headlamp.
9. If the Brake Signal Sync is turned on in the App, test the Brake Sync Channel 1 Override to ensure the Headlamp halo does not turn Red when the Brake is applied.
10. Properly Aim the headlamp for maximum performance.



ATTENTION

Please read all Information below before Installation

Important: Due to the increased light output from this unit, it is recommended you take the vehicle to a dealer to have the headlamp properly adjusted. Weight and tire pressure can affect the position of the light.

Warning: To prevent possible electrical shock, disconnect the negative battery terminal before installing this product.

1

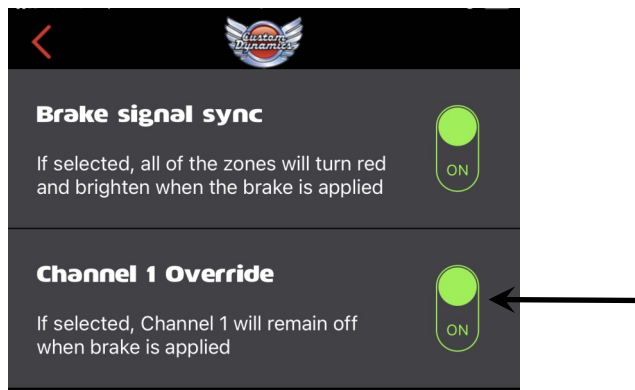

Questions? Call us at: 1 (800) 382-1388 M-TH 8:30AM-5:30PM / FR 9:30AM-5:30PM EST

Installation Instructions - Page 2

Non-Fairing Installation:

1. Disconnect the vehicle battery negative [-] terminal.
2. Review detailed service manual for instructions on replacing factory headlamp.
3. Remove the factory headlamp trim ring and headlamp from the headlamp bucket.
4. Drill a 5/8" hole in the back of the headlight bucket.
5. Route the ProGLOW™ wiring harness through the hole in the headlamp bucket and install the grommet.
6. Connect the 7" LED headlamp to the existing factory H4 plug.
7. Install headlamp and trim ring on the headlamp bucket.
8. Connect the ProGLOW™ wiring harness to Channel 1 of the ProGLOW™ Bluetooth Controller. Note: If the Brake Signal Sync is turned on in the App, The Channel 1 Override will need to be turned ON as shown in Photo1.
9. Re-connect vehicle battery negative [-] terminal.
10. Test high and low beam functions of headlamp.
11. If the Brake Signal Sync is turned on in the App, test the Brake Sync Channel 1 Override to ensure the Headlamp halo does not turn Red when the Brake is applied.
12. Properly Aim the headlamp for maximum performance.

NOTE:

Use caution when connecting the mating ProGLOW™ accessory connectors, confirm the mating connector is connected correctly or damage will occur to the lighting accessories. The locking tab should slide onto the lock and lock into position. See Photos below.

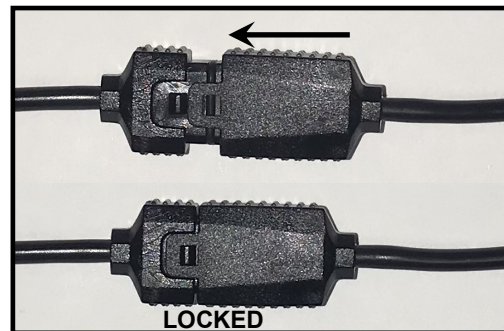

Using The H4-TOUR-ADAPTER on 2014-2023 H-D™ Touring Models

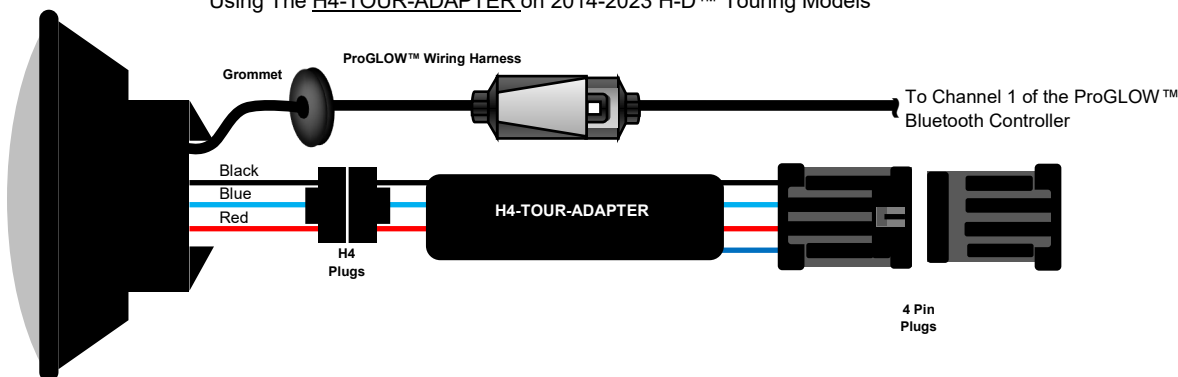

Using The CDTB-H42H9H11 (sold separately). on 2014-2023 H-D™ Road King/Freewheeler Models

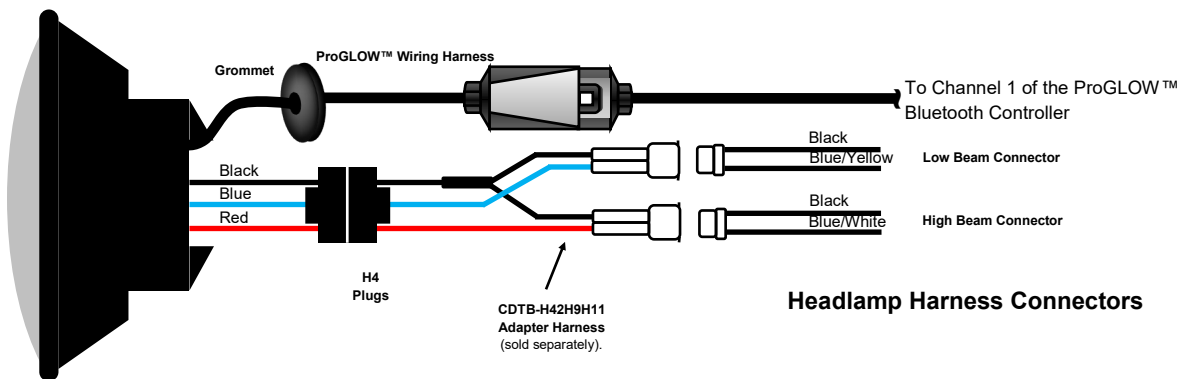

Questions? Call us at: 1 (800) 382-1388 M-TH 8:30AM-5:30PM / FR 9:30AM-5:30PM EST