



Custom Dynamics® Universal Turn Signal Decoder Installation Instructions

We thank you for purchasing the Custom Dynamics® Turn Signal Decoder. Our products utilize the latest technology and highest quality components to ensure you the most reliable service. We offer one of the best warranty programs in the industry and we back our products with excellent customer support, if you have questions before or during installation of this product please call Custom Dynamics® at 1(800) 382-1388.

Part Numbers: GEN-TSD-UNV

Package Contents:

- Turn Signal Decoder (1)

Fits: 2011-2013 Harley-Davidson® Softail Blackline (FXS), 2011-2012 CVO™ Softail Convertible (FLSTSE), 2012-2021 Softail Slim (FLS/FLSL), 2013-2020 Breakout (FXSB/FXSR), 2013-2014 CVO™ Breakout (FXSBSE), 2014-2015 CVO™ Softail Deluxe (FLSTNSE), 2016-2017 CVO™ Pro Street Breakout (FXSE), 2016-2017 Slim S (FLSS), 2018-2021 Street Bob (FXBB), Fat Bob (FXFB), Fat Boy (FLSTF) and Sport Glide (FXSB), 2020-2021 Softail Standard (FXST), 2012-2017 Dyna Street Bob (FXDB) and Wide Glide (FXDWG), 2016-2017 Low Rider S (FXDLS), 2014-2021 Iron 883 (XL883N) and Forty-Eight (XL1200X), 2014-2016 Seventy-Two (XL1200V), 2016-2020 Roadster (XL1200CX), 2018-2021 Iron 1200 (XL1200NS), 2018-2019 Forty-Eight Special (XL1200XS), 2014-2021 Tri Glide Ultra (FLHTCUTG), CVO™ Tri Glide (FLHTCUTGSE) & 2015-2021 Freewheeler (FLRT).

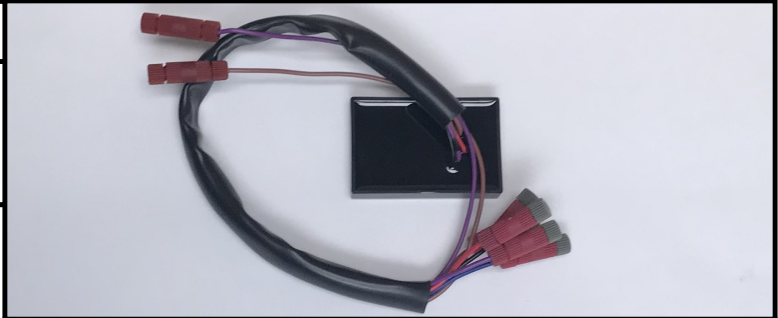

1. Remove the seat and locate the rear lighting wiring harness.
2. Select a good place for the Turn Signal Decoder unit that will not interfere with the placement of the seat. Secure with tie-wraps, tape or other means so that unit will not move.
3. Using the provided Posi-Taps™ connectors, connect the input wires of the Turn Signal Decoder to the bikes wiring harness. Refer to the wiring diagram on Page 2.
4. Using the provided Posi-Lock™ connectors, connect the turn signal only output wires from the Turn Signal Decoder to your accessory turn signals. Refer to the wiring diagram on Page 2.
5. Check operation of all lighting for proper operation.
6. Re-install seat.



ATTENTION



Please read all Information below before Installation

Warning: Disconnect negative battery cable from battery; refer to owner's manual. Failure to do so may result in electrical shock, injury, or fire. Secure negative battery cable away from positive side of battery and all other positive voltage sources on vehicle.

Safety First: Make sure the bike is parked on a level surface and bike's mechanical components are cool to the touch.

Questions? Call us at: 1 (800) 382-1388 M-TH 8:30AM-5:30PM / FR 9:30AM-5:30PM EST

Installation Instructions - Page 2

Installation (Continued)

Typical Motorcycle Wire Harness

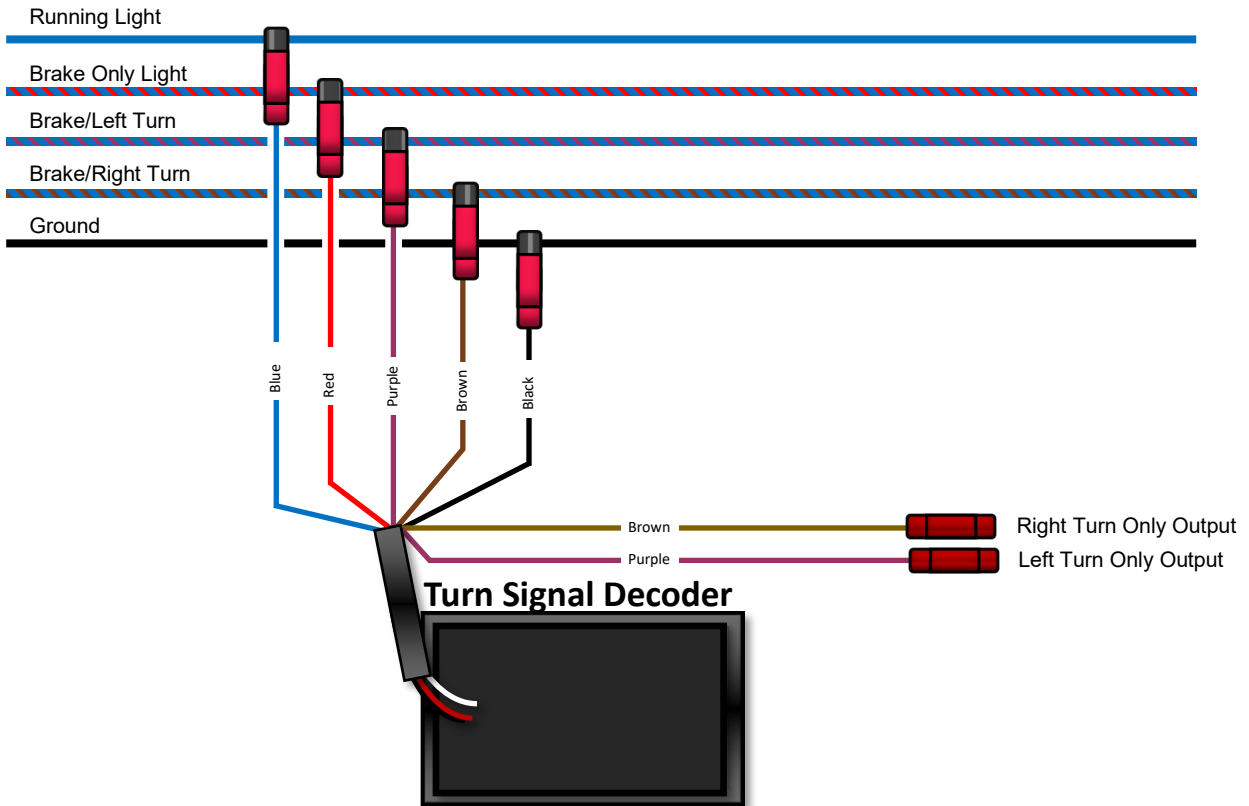

Posi-Tap™
TAP CONNECTOR

QUICK & EASY

- 1 Insert Hot Wire
- 2 Tighten
- 3 Strip Leads
- 4 Insert & Tighten

• TAPS WIRES WITHOUT CUTTING
• TOTAL WIRE INTEGRITY IS MAINTAINED
• INSTALLS IN SECONDS BY HAND
• NO CRIMPING OR TOOLS REQUIRED
• REUSABLE OR PERMANENT
• LESS RESISTANCE
• VIBRATION PROOF
• FULLY INSULATED

POWERS UP TO (4) LEADS AT ONCE!

NO CRIMPING

NO TOOLS NEEDED

Posi-Lock™ Connectors

EASY AS ①②③

- ① Strip wire 1/2"
- ② Insert
- ③ Hand tighten

CONNECTION COMPLETE!

Questions? Call us at: 1 (800) 382-1388 M-TH 8:30AM-5:30PM / FR 9:30AM-5:30PM EST