



Custom Dynamics® Genesis® Universal LED Clusters Installation Instructions

We thank you for purchasing the Custom Dynamics® Genesis® Universal LED Clusters. Our products utilize the latest technology and highest quality components to ensure you the most reliable service. We offer one of the best warranty programs in the industry and we back our products with excellent customer support. If you have questions before or during installation of this product please call Custom Dynamics® at 1(800) 382-1388.

**Part Numbers: GEN-(100/125/18)-R
GEN-(100/125/18)-A**

Package Content:

-Genesis® LED cluster (1)



Fitment: Universal



ATTENTION



Please read all Information below before Installation

Warning: Disconnect the negative battery cable from battery; refer to owner's manual. Failure to do so may result in electrical shock, injury or fire. Secure negative battery cable away from positive side of battery and all other positive voltage sources on vehicle.

Safety First: Make sure the bike is parked on a level surface and bike's mechanical components are cool to the touch.

Note: This product is designed and intended only for use as auxiliary lighting on motorcycles only. This product is NOT intended to replace any original equipment lighting installed on the motorcycle and should not be used for that purpose. This product must be wired such that it does not interfere with any original equipment lighting.

Installation:

1. Connect the black wire to vehicle ground.
2. Connect Orange wire to vehicle's constant power.
3. For GEN-(100/125/18)-R connect Red wire to vehicle's brake or rear turn signal power.

For GEN-(100/125/18)-A connect Yellow wire to vehicle's turn signal power.

Wiring Diagram

Black = Ground
Orange = Low Intensity (Constant Power)
Red = High Intensity (Brake or Rear Signal Power)
Yellow = High Intensity (Turn Signal Power)

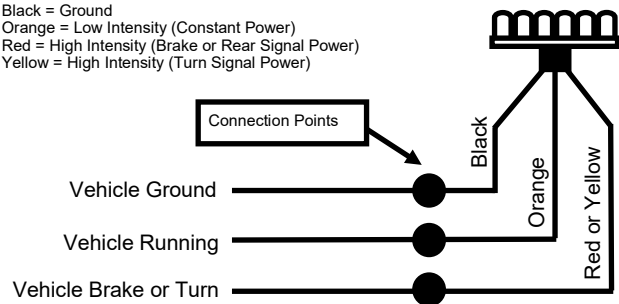

4. Test the function of the running light and brake or rear turn signals before riding.

Important Tips and Troubleshooting:

1. To troubleshoot issues with operation, first check for a good connection. If unsure of which wires are for running, and signal, use a test light and or a volt meter to confirm. If this does not correct issue, switch cluster to the other side and test or you may remove cluster to test for operation with a standalone power source such as a battery or power supply.
2. **Application:** This is designed to be used in the rear of the vehicle as a brake/signal light. If using this product with an aftermarket Run/brake/turn module, cap off the orange wire and do not use. Use the high intensity Red wire for the signal from the module. Use a clear, smoked or red lens.
3. Depending on vehicle and application you may experience fast flashing from your turn signals after installation. If so, a load equalizer or Signal Stabilizer™ is recommended. Contact us for details.

Questions? Call us at: 1 (800) 382-1388 M-TH 8:30AM-5:30PM / FR 9:30AM-5:30PM EST