



## Custom Dynamics® TruFLEX® Breakout LED Light Bar Installation Instructions

We thank you for purchasing the Custom Dynamics® TruFLEX® Breakout LED Light Bar! Our products utilize the latest technology and high quality components to ensure you the most reliable service. We offer one of the best warranty programs in the industry and we back our products with excellent customer support, if you have questions before or during installation of this product please call Custom Dynamics® at 1(800) 382-1388.

Part Numbers: CD-1054 CD-1054-B

### Package Contents:

- Array with TruFLEX LEDs (1)
- ISO Alcohol Pad (1)
- JB Weld SteelStik™ (1)
- Tie Wraps (10)
- Posi-Tap™ Connector (6)

**Fits:** 2018-2020 Harley Davidson® Softail Breakout (FXBR), Breakout 114 (FXBRS), 2016-2017 CVO™ Pro Street Breakout (FXSE), 2013-2017 Breakout (FXSB) & CVO™ Breakout (FXSBSE), and 2023-2024 Breakout 117 (FXBR).

Replaces OEM reflector and bracket PN 67900165

**Note:** It is highly recommended you perform installation of the array in a controlled constant temperature of 70 degrees F or above and allowing 24 hours for tape and putty to properly cure before riding or washing.



### Pre-Installation

1. Remove seat from the bike. If unsure of this procedure, please refer to your HD service manual. Disconnect the Negative [ - ] battery terminal from the battery.
2. Remove the fender from the bike by removing the 4 torx bolts from the strut support. If unsure of this process, please refer to your HD service manual. (See Figure 1)
3. Once the fender is off the bike, remove the 4 bolts to the inner fender support, remove the support which will allow removal of the stock reflector and bracket. (See Figures 2 & 3)
4. Clean the underside of the fender and prep with the provided ISO alcohol pad to make sure all road grime, grease and dirt is removed. For extremely dirty surfaces, a de-greaser is recommended first.

### Installation

5. Test fit the new array to find the appropriate mounting area, place under the fender and rest array against the bottom lip of the fender. Make sure it is centered, then mark the position with a pen or pencil for a guide.

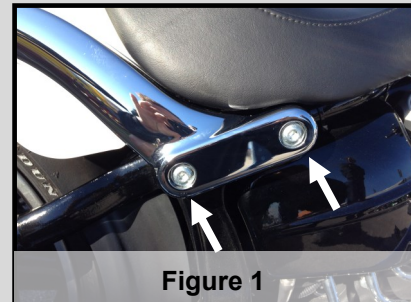

Figure 1

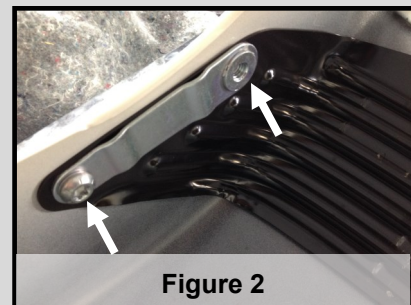

Figure 2

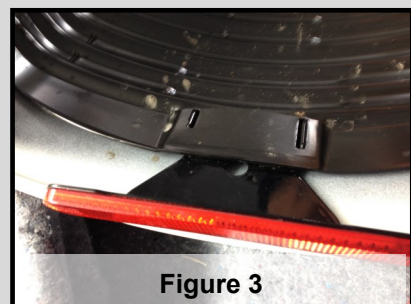

Figure 3

Questions? Email: [info@CustomDynamics.com](mailto:info@CustomDynamics.com) or Call us at: 1 (800) 382-1388 M-TH 8:30AM-5:30PM / FR 9:30AM-5:30PM EST

## Installation Instructions - Page 2

### Installation-Continued

6. Remove the red backing from the 3M Tape from one end and fold out towards you enough to grab onto, then carefully adhere to the inside of the fender, making sure array is aligned to your markings you made earlier. Once the desired location is set, pull the rest of the red backing off slowly and press firmly on the array until completely adhered to the fender. Allow 24 hours before riding or washing the bike.
7. Remove the SteelStik™ putty from the tube, then remove and read the directions included with the product. For this application you will Cut off approximately 1/3 from the stick. Knead the putty with fingers until it turns a uniform color. Roll the putty out into a 7" strip. Keep in mind Manufacturer states that the product has a 3-5 minute work life.
8. Ensure the surface that the putty is going to adhere to is free of dirt, grease and grime. Refer to pre-installation prep work on page 1.
9. Apply the putty to area of the light bar bracket between the wires, push into place filling the corner where the bracket meets the fender. Make sure it makes good contact with both surfaces. The Manufacturer states that the product has a cure time of 60 minutes. Allow 24 hours before riding or washing the bike.

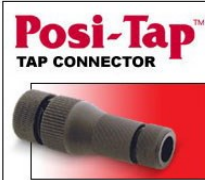





**Posi-Tap™**  
TAP CONNECTOR

- TAPS WIRES WITHOUT CUTTING
- TOTAL WIRE INTEGRITY IS MAINTAINED
- INSTALLS IN SECONDS BY HAND
- NO CRIMPING OR TOOLS REQUIRED
- REUSABLE OR PERMANENT
- LESS RESISTANCE
- VIBRATION PROOF
- FULLY INSULATED

**POWERS UP TO (4) LEADS AT ONCE!**

QUICK & EASY

- 1**  Insert Hot Wire
- 2**  Tighten
- 3**  Strip Leads
- 4**  Insert & Tighten



NO CRIMPING  
NO TOOLS NEEDED

### SteelStik™ Putty Installation

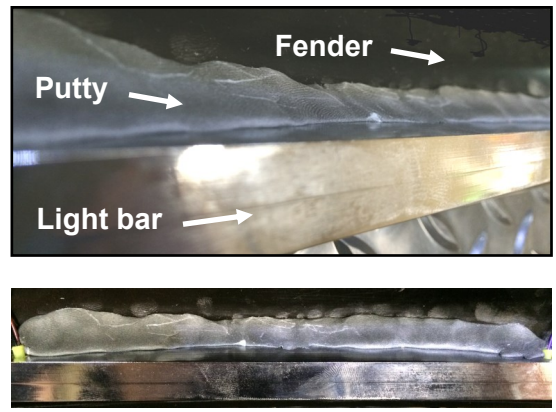

Fender →

Putty →

Light bar →

### Wiring

10. Route both sets of wires up each side of the fender, then re-install the inner fender support. Your wires will rest in between the support and the fender. Take care to run the wires where there is optimal clearance between the two.
11. Route wires along the fender harness, attach with tie wraps where needed. Follow the harness to a pair of 4 pin connectors located under the seat. The connector with the Purple wire is the left turn/brake and the connector with the Brown wire is the right turn/brake. (See diagram on page 3).
12. Using the included Posi-Tap™ connectors (see Posi-Tap™ instructions), attach the connectors to the wires in your harness, then trim any excess wire from light bar and attach to the other end of the Posi-Tap™ connectors. Using the following: (see wiring diagram on page 3)

Left Side:

Ground=Black to Black  
Running=Orange to Blue  
Brake/turn=Purple to Purple

2018-2023:

**Grey Connector**

Ground=Black to Black  
Running=Orange to Blue  
Brake/turn=Purple to Purple

Right Side:

Ground=Black to Black  
Running=Orange to Blue  
Brake/turn=Brown to Brown

2018-2023:

**Black Connector**

Ground=Black to Black  
Running=Orange to Blue  
Brake/turn=Purple to Purple

13. Once all connections have been made and are secure, reconnect the negative [ - ] battery terminal to the battery.
14. Test operation of the TruFLEX® Array in all modes, running, brake and turn.

# Installation Instructions - Page 3

## 2013-2017 Wiring Diagram

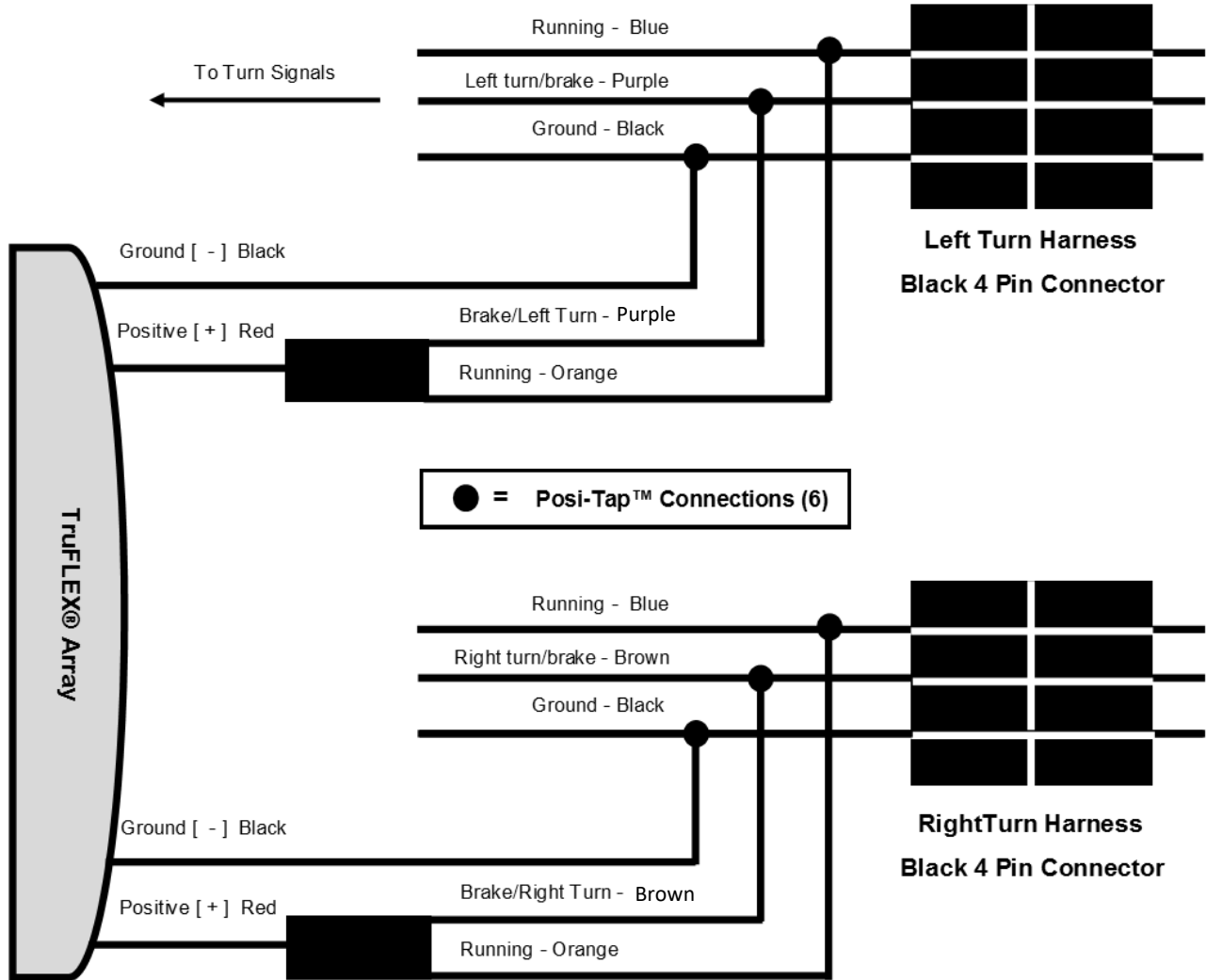

This product is designed and intended for use as auxiliary lighting on motorcycles only. This product is NOT intended to replace any original equipment lighting installed on the motorcycle and should not be used for that purpose. This product must be wired such that it does not interfere with any original equipment lighting.



# Installation Instructions - Page 4

## 2018-2024 Wiring Diagram

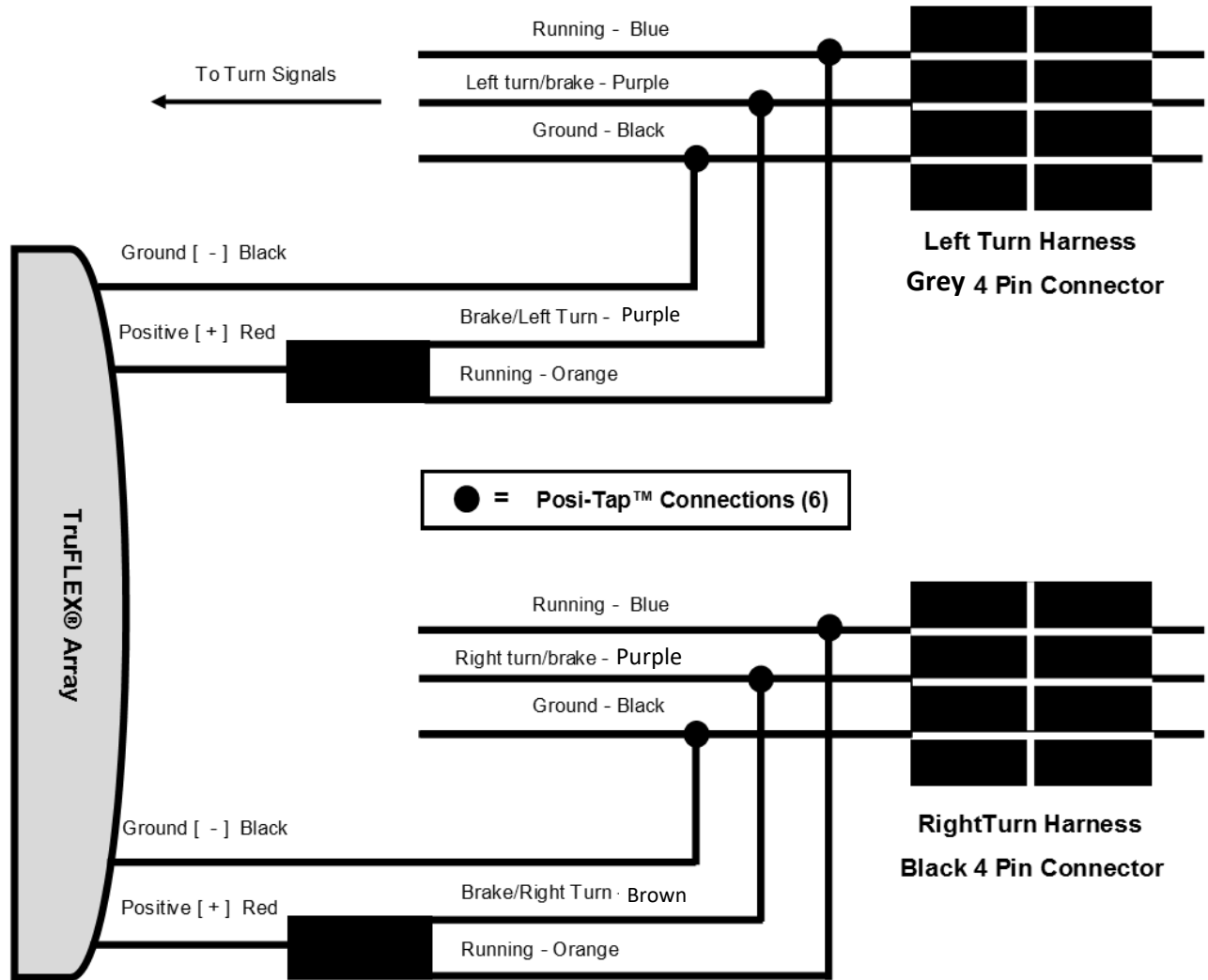

This product is designed and intended for use as auxiliary lighting on motorcycles only. This product is NOT intended to replace any original equipment lighting installed on the motorcycle and should not be used for that purpose. This product must be wired such that it does not interfere with any original equipment lighting.

