



Custom Dynamics® Magic Strobes™ Brake Flasher Installation Instructions

We thank you for purchasing the Custom Dynamics® Magic Strobes™ Brake Flasher Module. Our products utilize the latest technology and high quality components to ensure you the most reliable service. We offer one of the best warranty programs in the industry and we back our products with excellent customer support, if you have questions before or during installation of this product please call Custom Dynamics® at 1(800) 382-1388.

Part Number: MAGIC-STROBES-BCM XL

Package Contents:

- Magic Strobes™ Brake Flasher (1)
- Instructions

Fitment: 2014-2020 Harley-Davidson® Sportster® Iron 883 (XL883N), Iron 1200 (XL1200NS), Forty-Eight (XL1200X), Forty-Eight Special (XL1200XS), Seventy-Two (XL1200V), and Roadster (XL1200CS) **CAUTION:** Must be used with Low Power Current Draw LEDs such as Custom Dynamics®, The use of Incandescent or High Power LEDs (greater than 300ma) will cause the unit to fail.

Installation

1. Secure motorcycle on level surface. Remove seat. Disconnect negative battery cable from the battery. Locate and unplug the lighting connector to the rear fender.
2. Plug the Magic Strobes™ BCMXL module, in-line, into the rear lighting harness and into the bike's wiring harness.
3. Re-connect the battery's negative battery cable to the negative of the battery.
4. Locate a secure place for the Magic Strobes™ BCMXL unit that will not interfere with the secure placement of the seat or side cover. Use tie wraps or tape if needed.

Initial Setup and operation

5. Locate the two switches and rotary dial. Be sure the rotary dial is set to position 0. Note there is a screw driver slot to make the dial turn easier, this is not the pointer, there is small arrow on the dial, this is the pointer that should now be at position 0.
6. Make sure switch 1 & 2 are in the ON position.
7. Select the desired strobe setting listed below with the power off. Always turn power off before changing settings.
8. Turn power on and test for function of the turn signals, running and brake signals with desired setting.
9. Switch 1 enables you to turn the strobe feature on/off on the rear turn signals (if equipped), or other lights installed such as our TruFLEX® or other LEDs.
10. Switch 2 enables you the ability to turn on/off the center brake (if equipped) strobe signal.



Please read all information below before installation

CAUTION: Must be used with Low Power Current Draw LEDs such as Custom Dynamics®. The use of Incandescent or High Power LEDs (greater than 300ma) will cause the unit to fail.

Important: Dial and switches should be maneuvered by hand only. Do not use any tool such as a screwdriver that could damage waterproof covers.

Important: Module must be secured after installation. Find safe area away from any moving parts and out of the way of normal operation of the bike. Use tie-wraps or other means to secure. Custom Dynamics® is not liable for damage as a result of improperly securing or failing to secure the module.

Important: This module will not work properly if the settings in your BCM (body control module) have been modified from its stock factory configuration.

Note: Although this device has been designed to significantly increase your braking visibility, flash/strobe patterns may not be street legal in your area. This device is not DOT approved.

Questions? Call us at: 1 (800) 382-1388 M-TH 8:30AM-5:30PM / FR 9:30AM-5:30PM EST

Installation Instructions - Page 2

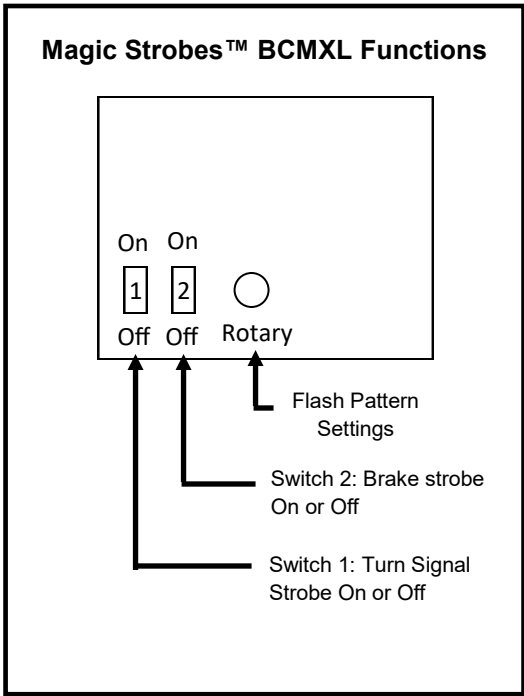

Flash Pattern Information:

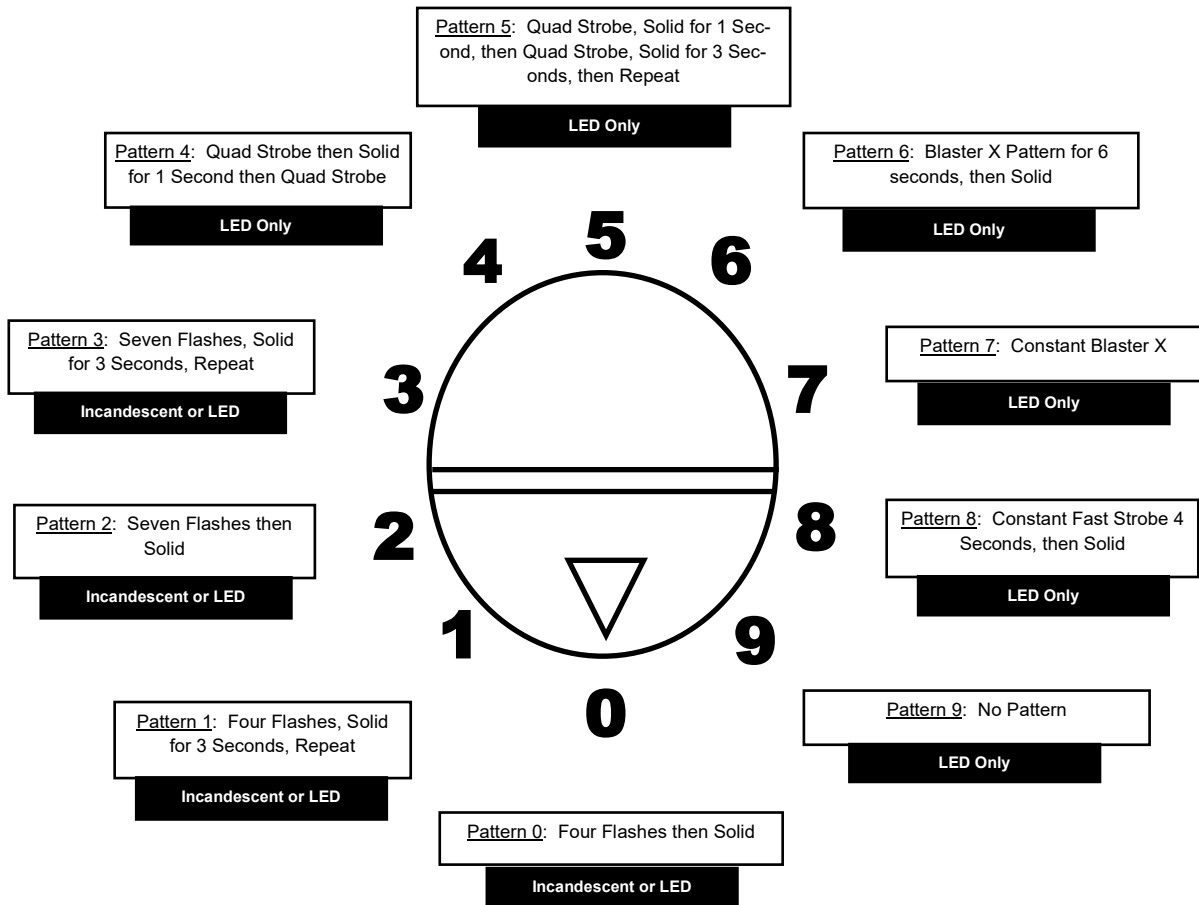

Questions? Call us at: 1 (800) 382-1388 M-TH 8:30AM-5:30PM / FR 9:30AM-5:30PM EST