



Custom Dynamics® Indian® Wiring Adapter Installation Instructions

We thank you for purchasing the Custom Dynamics® Indian® Wiring Adapter. Our products utilize the latest technology and highest quality components to ensure you the most reliable service. We offer one of the best warranty programs in the industry and we back our products with excellent customer support, if you have questions before or during installation of this product please call Custom Dynamics® at 1(800) 382-1388.

Part Numbers: MPR-IND

Package Contents:

- Indian® Wiring Adapter

Fits: 2014-2020 Indian® Chief®, Springfield™ and Roadmaster® Models (except 2020 Springfield Dark Horse, Chief Dark Horse & Roadmaster Dark Horse), 2014-2020 Chieftain® Classic, 2014-2019 Chieftain® Elite, 2014-2018 Chieftain®, Chieftain® Dark Horse, & Chieftain® Limited



ATTENTION



Please read all Information below before Installation

Warning: The auxiliary power circuit is power even when the bike is off. Its is critical to disconnect the negative battery cable from battery; refer to owner's manual. Failure to do so may result in electrical shock, injury, or fire. Secure negative battery cable away from positive side of battery and all other positive voltage sources on vehicle.

Safety First: Make sure the bike is parked on a level surface and bike's mechanical components are cool to the touch.

Installation:

1. Secure motorcycle on level surface. Confirm the ignition switch is in the off position. Remove the seat and disconnect the negative [-] battery cable from the battery.
2. Locate the rear fender lighting harness connectors under seat.
3. Unplug the connectors and plug the Indian® Wiring Adapter in-line with the rear fender lighting harness..
4. Connect wires as needed using installed Posi-Locks.

Black—Ground
Blue— Running
Red— Brake
Orange—Aux Power
Brown—Right Run/Brake/Turn (Models Without Center Taillight)
—Right Turn Only (Models With Center Taillight)
Purple—Left Run/Brake/Turn (Models Without Center Taillight)
—Left Turn Only (Models With Center Taillight)
6. Re-install seat and re-disconnect the negative [-] battery cable from the battery.
7. Check operation of all lights.

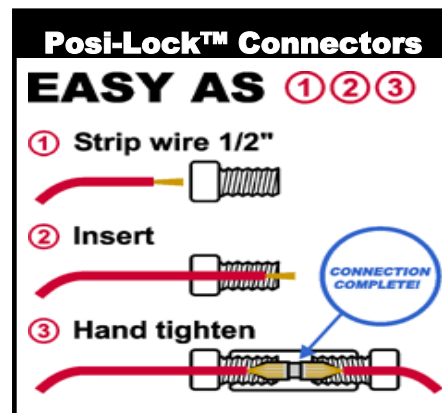

Questions? Call us at: 1 (800) 382-1388 M-TH 8:30AM-5:30PM / FR 9:30AM-5:30PM EST