

Custom Dynamics® ProBEAM® LED Headlamp Installation Instructions



We thank you for purchasing the Custom Dynamics® ProBEAM® LED headlamp! Our products utilize the latest technology and high quality components to ensure you the most reliable service. We offer one of the best warranty programs in the industry and we back our products with excellent customer support, if you have questions before or during installation of this product please call Custom Dynamics® at 1(800) 382-1388.

Part Number: PB-7-B PB-7-C

Package Contents:

- ProBEAM® LED Headlamp (1)
- Instructions

Fits: 1981-2021 Harley-Davidson® Electra Glide®, Ultra, Street Glide® and Tri Glide® models (including CVO™; [H4-TOUR-ADPT](#) required for plug and play installation on 2014-2021 models). 1994-2021 Road King® models (including CVO™; [CDTB-H42H9H11](#) adapter required for plug and play installation on 2014-2021 models). 2015-2021 Free-wheeler®. 2012-2016 Dyna® Switchback. 1984-2017 FL Soft-tail® models with OEM 7" headlight buckets.

Metric Adapters sold separately.

⚠ ATTENTION ⚠

Please read all Information below before Installation

Important: Due to the increased light output from this unit, it is recommended you take the vehicle to a dealer to have the headlamp properly adjusted. Weight and tire pressure can affect the position of the light.

Warning: To prevent possible electrical shock, disconnect the negative battery terminal before installing this product.

Fitment Note: 2014-2021 Harley-Davidson® Street Glide®, Electra Glide®, and TriGlide® Models require **H4-TOUR-ADPT** for plug and play installation of ProBEAM® Headlamp. Be sure to secure the spade connector to the H4-TOUR ADAPTER using wire ties (see page 2).

Fitment Note: 2014-2021 Road King® models require **CDTB-H42H9H11** adapter for plug and play installation of ProBEAM® Headlamp. (see page 2)

Installation:

1. Disconnect the vehicle battery negative [-] terminal.
2. Review detailed service manual for instructions on replacing factory headlamp.
3. Remove the factory headlamp from vehicle.
4. Connect the ProBEAM® headlamp to the existing factory H4 plug and re-install according to your detailed service manual. Make sure no wire or any components of the harness can be pinched during installation and that they will not be exposed to water spray, excessive heat or moving parts.

Note: The Red (position light or city light) wire is intended for international application which may require a position light to be illuminated in the headlight while the bike is parked on a street. It will be connected to the accessory circuit of the bike's harness and will illuminate when the ignition is placed in the accessory position.

U.S. Bikes will not need this and it should be secured to the headlight harness with wire ties.

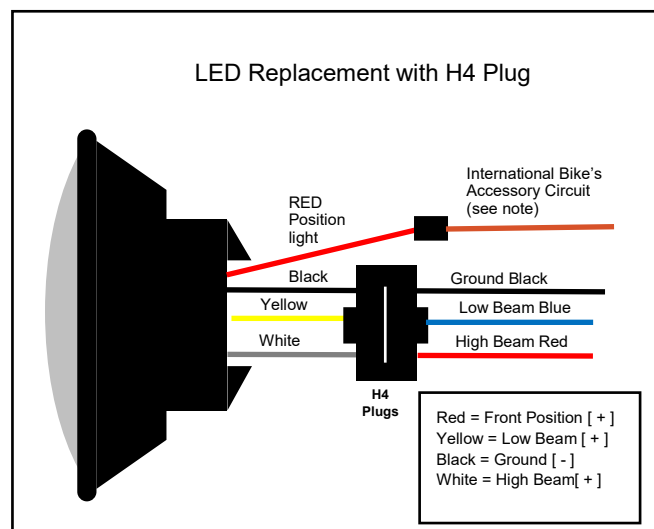

Questions? Call us at: 1 (800) 382-1388 M-TH 8:30AM-5:30PM / FR 9:30AM-5:30PM EST

Installation Instructions - Page 2

5. Re-connect vehicle battery negative [-] terminal.
6. Test high and low beam functions of headlamp.

Note: 2014-2021 H-D™ If your headlight electrical harness connector does not match the flat 4 pin connector of the H4-TOUR-ADAPTER, follow your bike's harness back into the fairing until you find your bike's flat 4 pin connector.

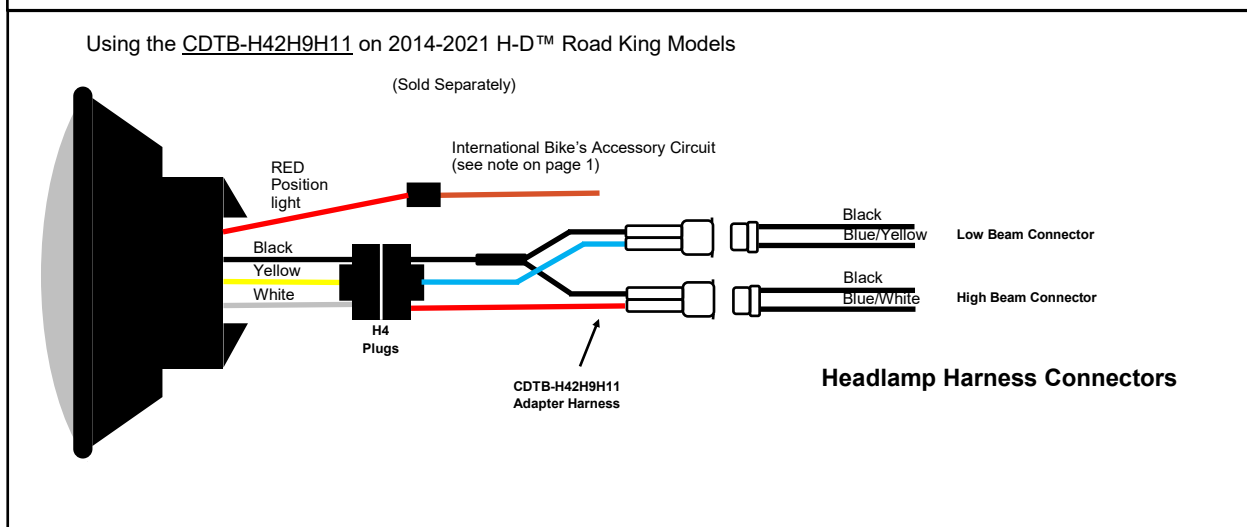
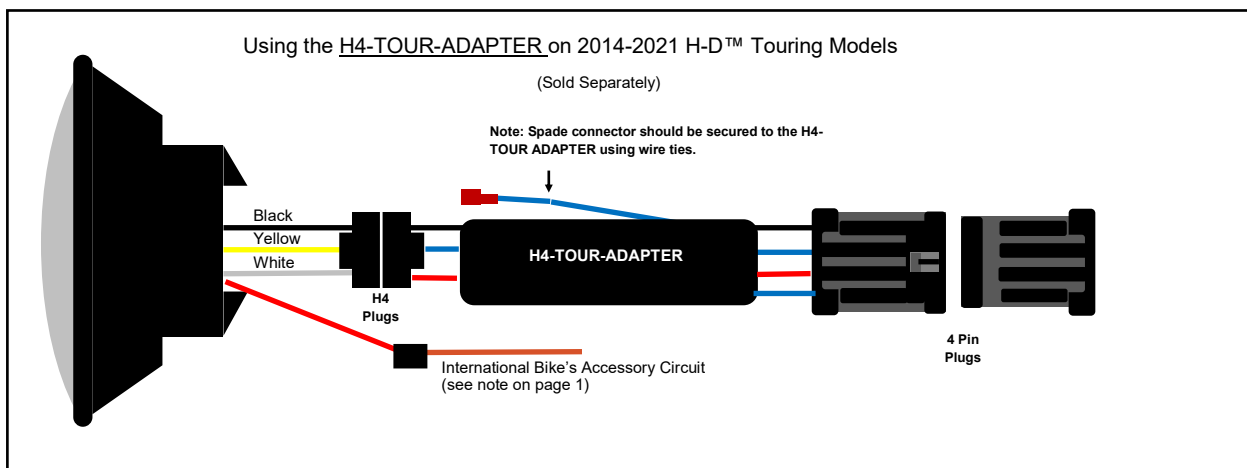

Questions? Call us at: 1 (800) 382-1388 M-TH 8:30AM-5:30PM / FR 9:30AM-5:30PM EST