

# PROBEAM®

BY CUSTOM DYNAMICS®

## ProBEAM® Saddlebag LED Lights Installation Instructions

We thank you for purchasing the Custom Dynamics® ProBEAM® Saddlebag LED Lights. Our products utilize the latest technology and highest quality components to ensure you the most reliable service. We offer one of the best warranty programs in the industry and we back our products with excellent customer support. If you have questions before or during installation of this product please call Custom Dynamics® at 1(800) 382-1388.

Part Numbers: PB-SB-BCM-BR PB-SB-BCM-BS  
PB-SB-BCM-CR PB-SB-BCM-CS

US Patent: D875977, D876,691S  
China Patent: ZL201 930037082.0

### Package Contents:

- Saddle Bag LED Light W/ Quick Disconnect Harness (2)
- BCM Y Harness Adapter w/ Plugs (1)
- 4" Tie Wraps (10)
- Cable Tie Holders (6)

**Fits:** 2014-2022 Harley-Davidson® Street Glide (FLHX), Street Glide Special (FLHXS), Street Glide ST (FLHXST), Street Glide CVO (FLHXSE), Road Glide (FLTRX), Road Glide Special (FLTRXS), Road Glide ST (FLTRXST), Road Glide CVO™ (FLTRXSE), Road Glide Ultra (FLTRU), Road Glide Limited (FLTRK), Road Glide Limited CVO (FLTRKSE), Ultra Classic (FLHTCU), Ultra Classic Low (FLHTCUL), Ultra Limited (FLHTK), Ultra Limited Low (FLHTKL), Limited CVO™ (FLHTKSE), Road King (FLHR), Road King Special (FLHRXS), 2014 Road King CVO (FLHRSE), 2015-2016 Road Glide Ultra CVO™ (FLTRUSE) and 2019-2022 Electra Glide Standard (FLHT).



### Installation:

1. Test fit the Saddle Bag Lights, on each bag. The light should mount a couple millimeters below the bottom edge of the lid when the lid is closed. Mark the location with a grease pencil.
2. Clean the surface area location with denatured alcohol. Allow 1-2 minutes to dry.
3. Remove the red adhesive backing and install the lights on the left and right saddle bags. Press firmly into place.
4. Remove both bags from the bike.
5. Clean the surface area locations for the tie wrap holders with alcohol. Remove paper backing from cable tie holders and press into place (See Picture 1).
6. Route wires from bag light to each tie wrap holder location and secure with enclosed tie wraps.
7. Remove seat from bike and locate rear main wire harness.
8. Plug BCM Y harness adapter into rear wiring harness.
9. Route the wires on the harness adapter out from under the seat and towards saddle bags.
10. Reinstall saddle bags. Connect 3 pin plugs from bag lights to Y adapter making sure female with purple wire plugs in male with purple wire, and female with brown wire plugs into male with brown wire. (See different configurations on page 2)
11. Secure wires with the included tie wraps, make sure wiring will not come in contact with moving parts or in an area with high heat. Also take care that wires will not get pinched or frayed then reinstall seat.
12. Perform a BCM sync by turning key on, turn 4 way hazards on, turn key off. Allow hazards to run for 3-4 minutes. Turn Key on, Turn Hazards off, Turn Key off.
13. Test operation of running, brake and turn signal lights.

## ⚠ ATTENTION ⚠

**Disclaimer:** Removal of our saddlebag lights after installation, may cause permanent damage to the finished surface area of the saddlebag.

**Warning:** Disconnect negative battery cable from battery; refer to owner's manual. Failure to do so may result in electrical shock, injury or fire. Secure negative battery cable away from positive side of battery and all other positive voltage sources on vehicle.

**Safety First:** Always wear appropriate safety gear including safety glasses when performing any electrical work. It is highly recommended that safety glasses be worn throughout this installation process. Be sure vehicle is on level surface, secure and cool.

**Important:** This product is designed and intended for use as auxiliary lighting only. It is NOT intended to replace any original equipment lighting installed on the vehicle and should not be used for that purpose. This product must be wired so that it does not interfere with any original equipment lighting.

**Note:** The Y Harness Adapter must be plugged into the output (behind) any brake strobe modules.



BAGZ™ come with plug and play weatherproof quick disconnect to make future removal of saddlebags quick and easy (see pictures below).



Questions? Call us at: 1 (800) 382-1388 M-TH 8:30AM-5:30PM / FR 9:30AM-5:30PM EST

# Installation Instructions - Page 2

## Original Configuration

Functions listed on page 1

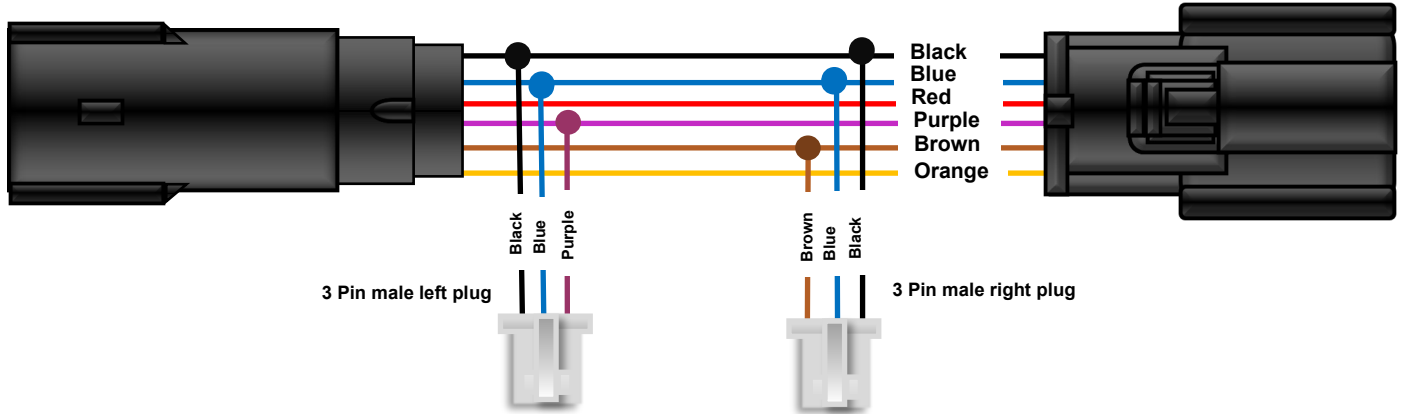

## Run-Brake Modification

\*Purple and Brown Wires going from the 3 Pin Connectors to the Y Harness must be cut and moved from the Purple and Brown to the Red

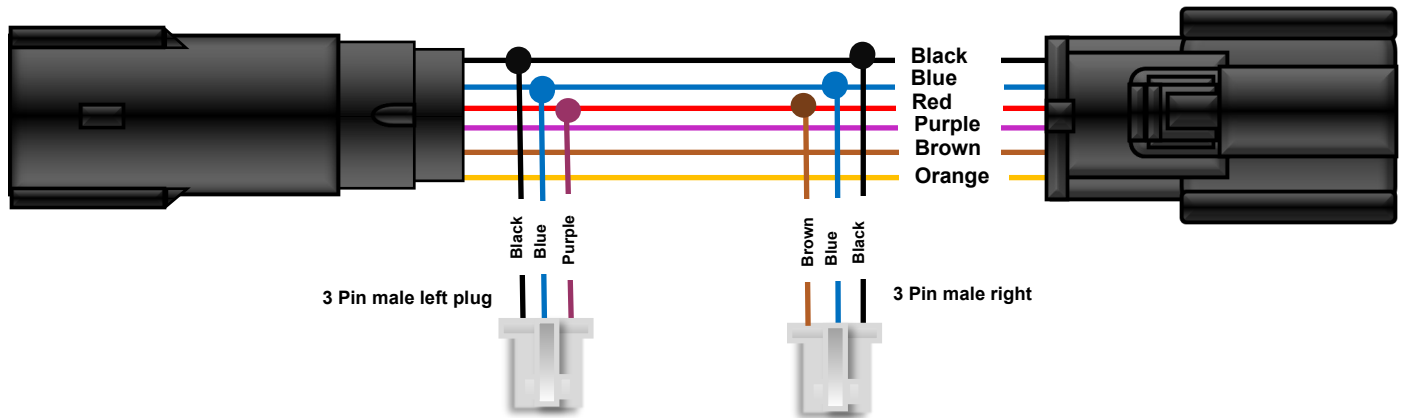

Questions? Call us at: 1 (800) 382-1388 M-TH 8:30AM-5:30PM / FR 9:30AM-5:30PM EST

## Installation Instructions - Page 3

MPR-BCM-PLUG Diagram with ProBEAM Bagz™ as Run-Brake and Turn using PB-EPZ (sold separately)

2019-2022 Electra Glide® Standard (FLHT), 2014-2022 Road King® Standard, 2014-2015 Limited CVO™, & 2015 Road Glide Ultra CVO™ Run-Brake-Turn \*PB-EPZ required for run, brake, turn function (sold separately)

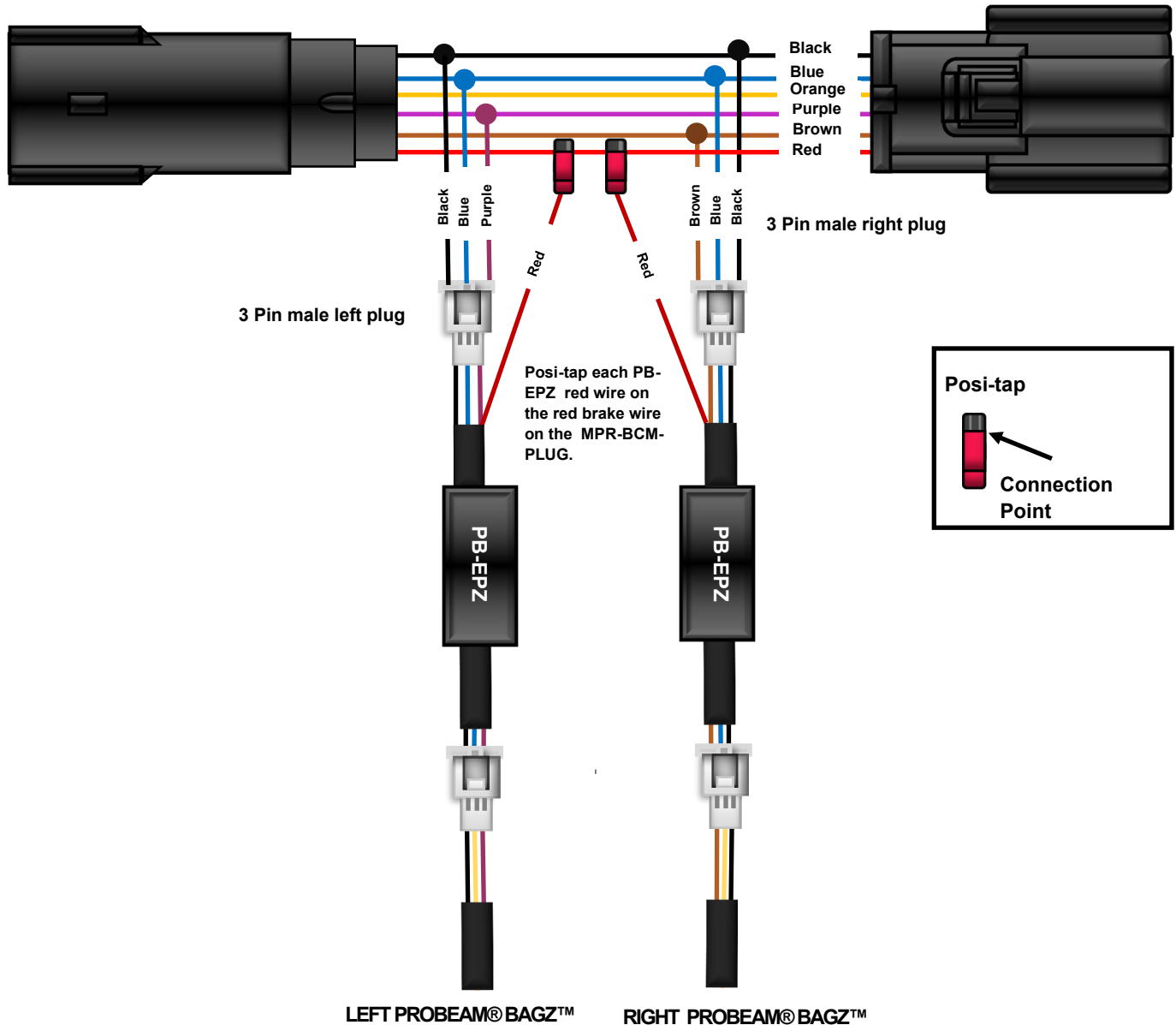

Questions? Call us at: 1 (800) 382-1388 M-TH 8:30AM-5:30PM / FR 9:30AM-5:30PM EST