

PROBEAM®

BY CUSTOM DYNAMICS®

ProBEAM® Saddlebag LED Lights Installation Instructions

We thank you for purchasing the Custom Dynamics® ProBEAM® Saddlebag LED Lights. Our products utilize the latest technology and highest quality components to ensure you the most reliable service. We offer one of the best warranty programs in the industry and we back our products with excellent customer support. If you have questions before or during installation of this product please call Custom Dynamics® at 1(800) 382-1388.

Part Numbers: PB-SB-BCM-BR PB-SB-BCM-BS

PB-SB-BCM-CR PB-SB-BCM-CS

US Patent: D875977, D876,691S

China Patent: ZL201 930037082.0

Package Contents:

- Saddle Bag LED Light W/ Quick Disconnect Harness (2)
- BCM Y Harness Adapter w/ Plugs (1)
- 4" Tie Wraps (10)
- Cable Tie Holders (6)

Fits: 2014-2024 Harley-Davidson® Ultra Limited (FLHTK), 2014-2023 Street Glide (FLHX), Street Glide Special (FLHXS), 2015-2023 Road Glide (FLTRX), Road Glide Special (FLTRXS), 2017-2024 Road King Special (FLHRXS), 2014-2022 Road King (FLHR), 2022-2023 Street Glide ST (FLHXST), Road Glide ST (FLTRXST) & CVO™ Road Glide Limited (FLTRKSE), 2020-2024 Road Glide Limited (FLTRK), 2015-2022 CVO™ Street Glide (FLHXSE), 2018-2022 CVO™ Road Glide (FLTRXSE), 2019-2022 Electra Glide Standard (FLHT), 2014-2019 Electra Glide Ultra Classic (FLHTCU), 2015-2016 Ultra Classic Lo (FLHTCUL) & CVO™ Road Glide Ultra (FLTRUSE), 2016-2019 Road Glide Ultra (FLTRU), 2015-2018 Ultra Limited Lo (FLHTKL), 2014-2021 CVO™ Limited (FLHTKSE) and 2014 CVO™ Road King (FLHRSE).

Functions as Run/Brake/Turn on 2014-2024 Harley-Davidson® Ultra Limited (FLHTK), 2014-2023 Street Glide (FLHX), Street Glide Special (FLHXS), 2015-2023 Road Glide (FLTRX), Road Glide Special (FLTRXS), 2017-2024 Road King Special (FLHRXS), 2014-2022 Road King (FLHR), 2014-2019 Ultra Classic (FLHTCU), Ultra Classic Lo (FLHTCUL), Ultra Limited Lo (FLHTKL), Road Glide Ultra (FLTRU), 2020-2024 Road Glide Limited (FLTRK), 2016 Road Glide Ultra CVO (FLTRUSE), 2022-2023 Road Glide Limited CVO (FLTRKSE) and 2016-2022 Limited CVO (FLHTKSE).

Functions as Run/Turn on 2014-2023 Harley-Davidson® Road King (FLHR), Street Glide ST (FLHXST), Street Glide CVO (FLHXSE), Road Glide ST (FLTRXST), Road Glide CVO (FLTRXSE), 2014 Road King CVO (FLHRSE), 2015 Road Glide Ultra CVO (FLTRUSE), 2014-2015 Ultra Limited CVO (FLHTKSE), 2014-2018 Electra Glide Police (FLHTP) and 2019-2022 Electra Glide Standard (FLHT).

⚠ ATTENTION ⚠

Disclaimer: Removal of our saddlebag lights after installation, may cause permanent damage to the finished surface area of the saddlebag.

Warning: Disconnect negative battery cable from battery; refer to owner's manual. Failure to do so may result in electrical shock, injury or fire. Secure negative battery cable away from positive side of battery and all other positive voltage sources on vehicle.

Safety First: Always wear appropriate safety gear including safety glasses when performing any electrical work. It is highly recommended that safety glasses be worn throughout this installation process. Be sure vehicle is on level surface, secure and cool.

Important: This product is designed and intended for use as auxiliary lighting only. It is NOT intended to replace any original equipment lighting installed on the vehicle and should not be used for that purpose. This product must be wired so that it does not interfere with any original equipment lighting.

Note: The Y Harness Adapter must be plugged into the output (behind) any brake strobe modules.



Installation:

1. Test fit the Saddle Bag Lights, on each bag. The light should mount a couple millimeters below the bottom edge of the lid when the lid is closed. Mark the location with a grease pencil.
2. Clean the surface area location with denatured alcohol. Allow 1-2 minutes to dry.
3. Remove the red adhesive backing and install the lights on the left and right saddle bags. Press firmly into place.
4. Remove both bags from the bike.
5. Clean the surface area locations for the tie wrap holders with alcohol. Remove paper backing from cable tie holders and press into place (See Picture 1).
6. Route wires from bag light to each tie wrap holder location and secure with enclosed tie wraps.
7. Remove seat from bike and locate rear main wire harness.
8. Plug BCM Y harness adapter into rear wiring harness.
9. Route the wires on the harness adapter out from under the seat and towards saddle bags.
10. Reinstall saddle bags. Connect 3 pin plugs from bag lights to Y adapter making sure female with purple wire plugs in male with purple wire, and female with brown wire plugs into male with brown wire. (See different configurations on page 2)
11. Secure wires with the included tie wraps, make sure wiring will not come in contact with moving parts or in an area with high heat. Also take care that wires will not get pinched or frayed then reinstall seat.

BAG™ come with plug and play weatherproof quick disconnect to make future removal of saddlebags quick and easy (see pictures below).



Questions? Email: info@CustomDynamics.com or Call us at: 1 (800) 382-1388 M-TH 8:30AM-5:30PM / FR 9:30AM-5:30PM EST

Installation Instructions - Page 2

Original Configuration

Functions as **Run/Brake/Turn** on 2014-2023 Harley-Davidson® Street Glide (FLHX), Street Glide Special (FLHXS), Road Glide (FLTRX), Road Glide Special (FLTRXS), Road King Special (FLHRXS), Ultra Classic (FLHTCU), Ultra Classic Lo (FLHTCUL), Ultra Limited (FLHTK), Ultra Limited Lo (FLHTKL), Road Glide Ultra (FLTRU), Road Glide Limited (FLTRK), 2016 Road Glide Ultra CVO (FLTRUSE), 2022-2023 Road Glide Limited CVO (FLTRKSE) and 2016-2022 Limited CVO (FLHTKSE).

Functions as **Run/Turn** on 2014-2023 Harley-Davidson® Road King (FLHR), Street Glide ST (FLHXST), Street Glide CVO (FLHXSE), Road Glide ST (FLTRXST), Road Glide CVO (FLTRXSE), 2014 Road King CVO (FLHRSE), 2015 Road Glide Ultra CVO (FLTRUSE), 2014-2015 Ultra Limited CVO (FLHTKSE), 2014-2018 Electra Glide Police (FLHTP) and 2019-2022 Electra Glide Standard (FLHT).

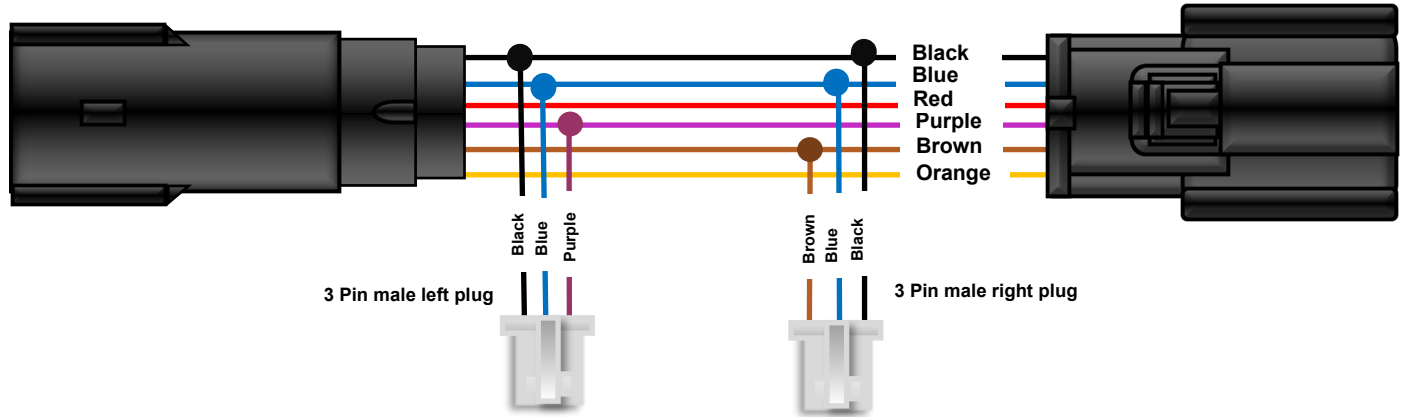

Run-Brake Modification

*Purple and Brown Wires going from the 3 Pin Connectors to the Y Harness must be cut and moved from the Purple and Brown to the Red

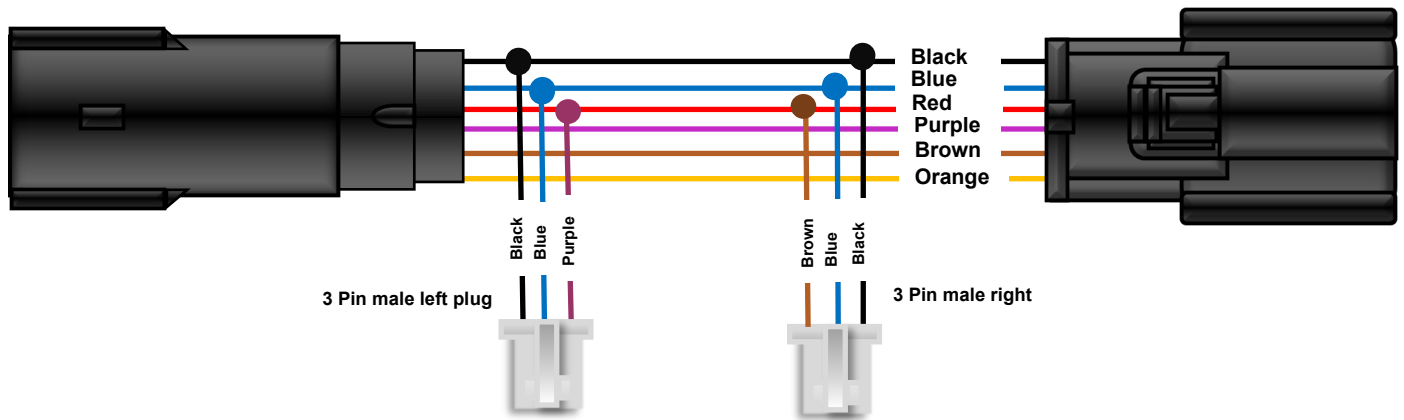

Installation Instructions - Page 3

MPR-BCM-PLUG Diagram with ProBEAM Bagz™ as Run-Brake and Turn using PB-EPZ (sold sepa-

2014-2023 Harley-Davidson® Road King (FLHR), Street Glide ST (FLHXST), Street Glide CVO (FLHXSE), Road Glide ST (FLTRXST), Road Glide CVO (FLTRXSE), 2014 Road King CVO (FLHRSE), 2015 Road Glide Ultra CVO (FLTRUSE), 2014-2015 Ultra Limited CVO (FLHTKSE), 2014-2018 Electra Glide Police (FLHTP) and 2019-2022 Electra Glide Standard (FLHT). Run-Brake-Turn *PB-EPZ required for run, brake, turn function (sold separately)

