



## Custom Dynamics® Red Plasma Rods™ Installation Instructions

We thank you for purchasing the Custom Dynamics® LED Plasma Rods™! Our products utilize the latest technology and high quality components to ensure you the brightest, most reliable LED's on the market. We offer one of the best warranty programs in the industry and we back our products with excellent customer support, if you have questions before or during installation of this product please call Custom Dynamics® at 1(800) 382-1388.

### Package Includes:

- Red Plasma Rods™ (pair)
- Posi-Taps® (3)

### Optional Items Purchased Separately:

- Dual Converter (for dual function)
- Smart Triple Play® (Run, Brake, Turn Controller)
- Eclipse2 Module™ (for Brake/turn)
- MPR-BCM (adapter for 2014-2021 HD Touring)
- MPR-SS6 (adapter for 2010-2013 Street Glide®, 2010-2013 Road Glide® Custom
- MPR-SS8 (adapter for 2010-2012 Street Glide® CVO™, 2009 Road Glide® CVO™, 2012-2013 Road Glide® Custom CVO™ and 2013 Road King® CVO™
- Universal Adapter (adapter for 1996-2017 Softails (except Breakout, Slim/Slim-S & Blackline), 1997-2017 Dynas (except FXDB & FXDWG), 1997-2013 Touring (except Street Glide & Road Glide Custom), and 1999-2003 Sportsters, 2010-2013 HD Trikes; 2011-2013 Road Glide Ultra

**Fits:** Works on all 12VDC negative ground systems

### Installation:

1. Select location for mounting the Plasma Rods™, a typical area on most baggers is the outer edge of the filler strip area. For different applications, make sure that you have enough flat surface to properly adhere to.
2. Clean the selected location with denatured alcohol, allow 4-5 minutes to dry.
3. Mount the Plasma Rod with the wire on top. Remove a few inches of the red backing from the tape on one end, fold towards you for enough to grab onto to remove the rest in a minute. Attach the end of the Plasma Rod™ to the desired location, once started, slowly pull on the red backing to remove, pressing down on the rod as you go until completely adhered.

### Wiring Options:

Depending on your bike's equipment, there are different options for the function of the Plasma Rods™. The wiring diagrams on page 2 shows the function combinations. If you have a Run/brake/turn module installed, or have a bike without a center tail light, see the wiring diagrams on page 3. Please note that for some of the different functions, additional items may be required. For 2014-2022 HD Touring, see page 4.

Using the supplied Posi-Tap™ Connectors, follow the wiring instructions below:

4. Connect Black wire to good ground.
5. Connect Red wire to 12VDC power source such as brake or turn signal wire, depending on use.
6. If Dual Converter is to be used, connect red wire on the Plasma Rod™ to the single red wire side of the dual converter. Connect red wire on opposite end to brake or turn signal power source and the orange to 12VDC running light source.
7. If EPZ2 Module™ converter is to be used, connect red and black wires to red and black wires of EPZ2 Module™ (2 wire side). Connect red wire on opposite end to brake power source, orange wire to turn signal source, and black wire to the ground.
8. Check operation of Plasma Rod™ in all modes.

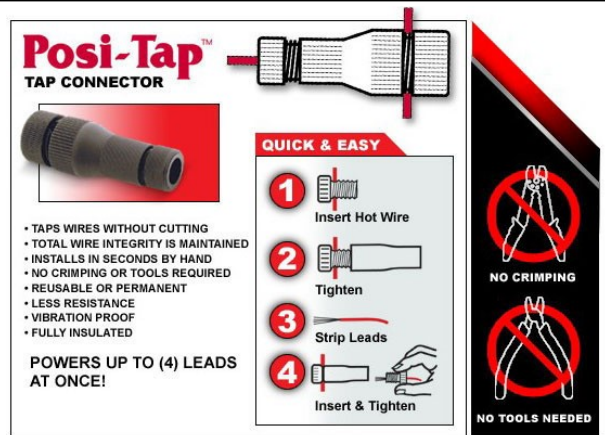

This product is designed and intended for use as auxiliary lighting only. It is NOT intended to replace any original equipment lighting installed on the vehicle and should not be used for that purpose. This product must be wired so that it does not interfere with any original equipment lighting.

**Note:** Install the Plasma Rods with the wire coming out at the top.

Questions? Call us at: 1 (800) 382-1388 M-TH 8:30AM-5:30PM / FR 9:30AM-5:30PM EST

# Installation Instructions - Page 2

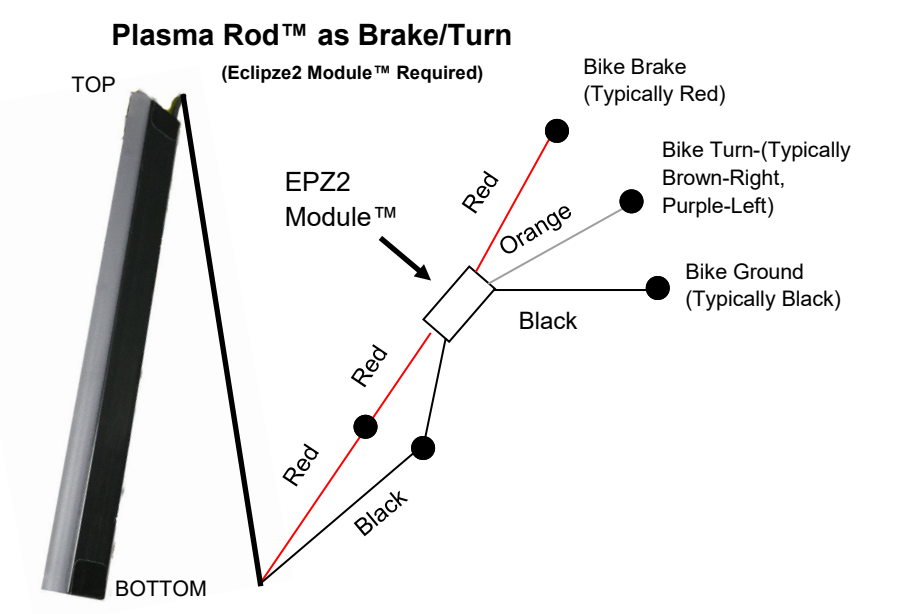
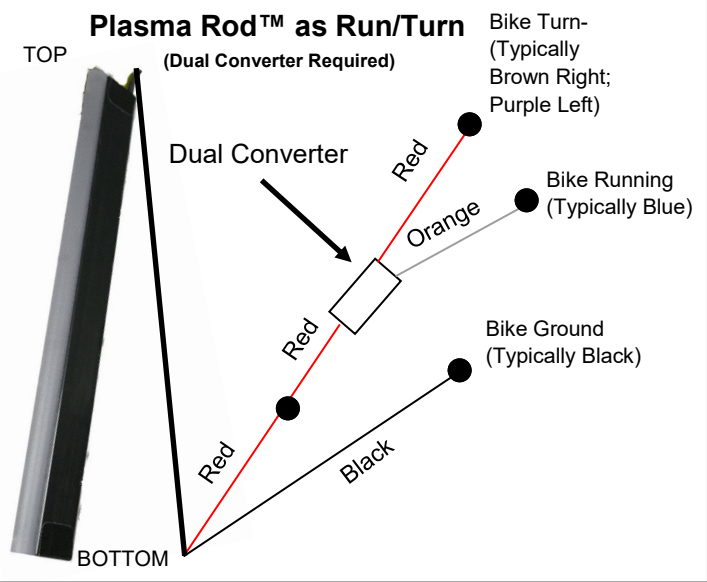
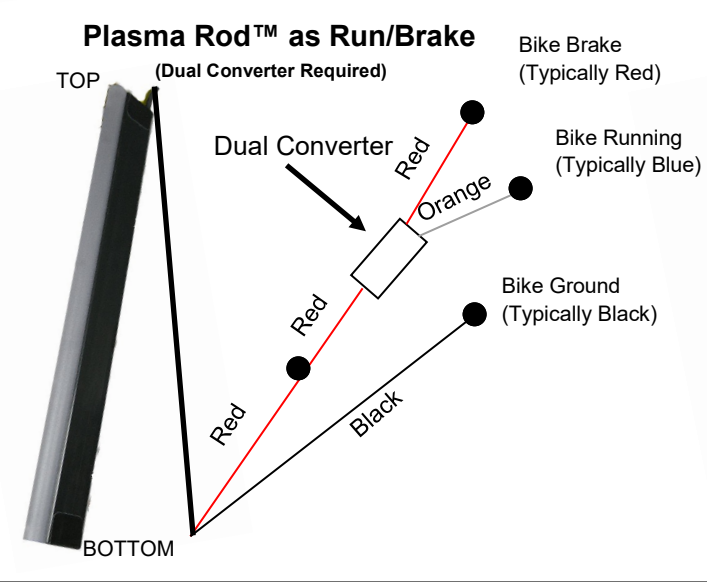
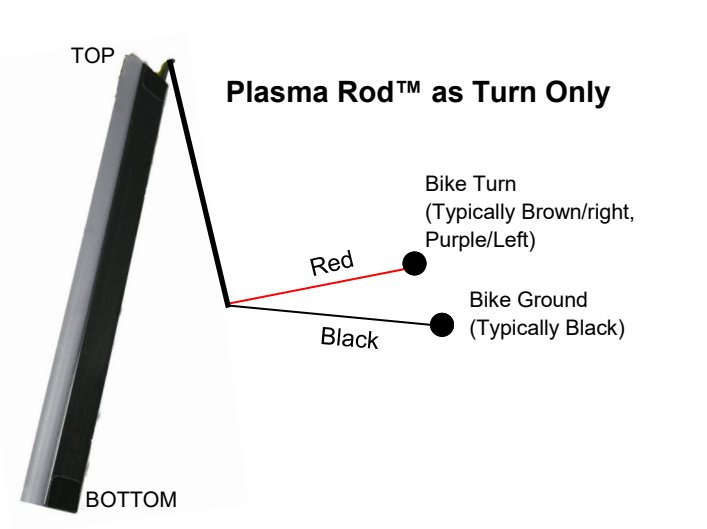
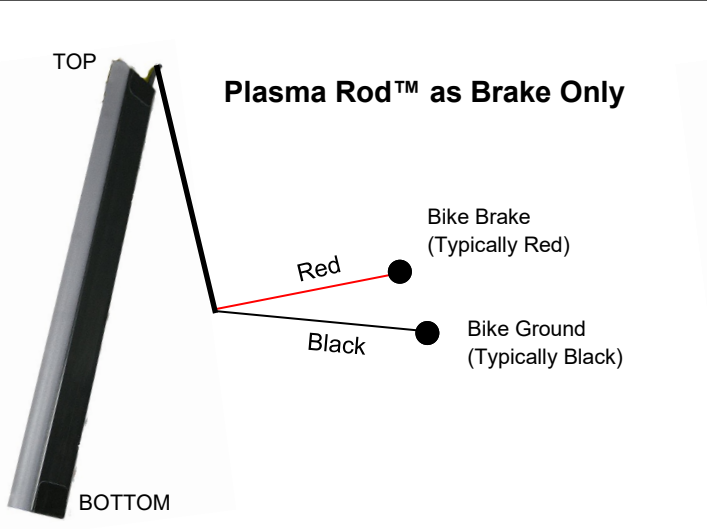

● = **Connection Points**

**Note:** Wire colors referenced in diagrams are based on the wiring harness colors for Harley-Davidson Motorcycles. Please refer to your manufacturer service manual for wiring color codes for different makes. Always confirm your bike's wiring with a test light to make sure you are tapping into the correct wires.

Questions? Call us at: 1 (800) 382-1388 M-TH 8:30AM-5:30PM / FR 9:30AM-5:30PM EST

# Installation Instructions - Page 3

## Plasma Rod™ as Run/Brake/Turn on Bike with After Market Run-Brake-Turn Controller

(Controller Sold Separately)

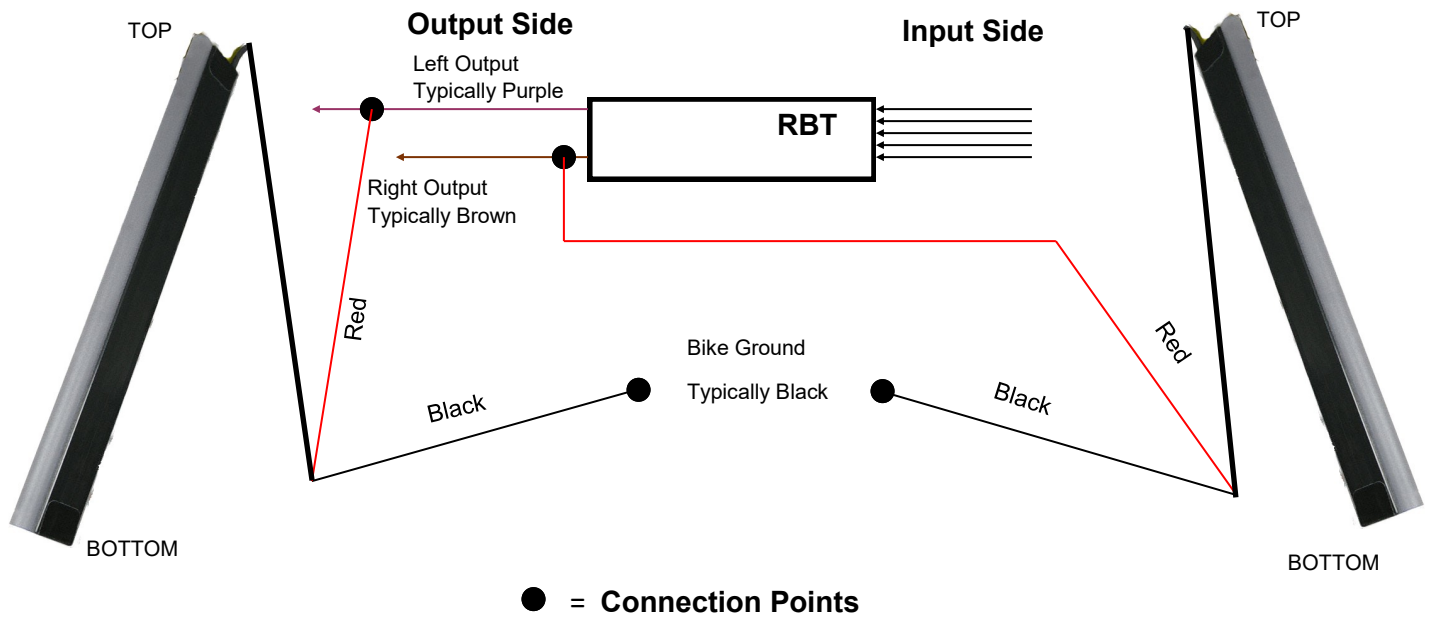

## Plasma Rod™ as Run/Brake/Turn on 2010-2013 Street Glide & Road Glide Custom

Remove back cover of Tri-bar to access output, right side of Tri-Bar. Use 12 volt test Light to determine which purple wire is left turn and which is right turn.

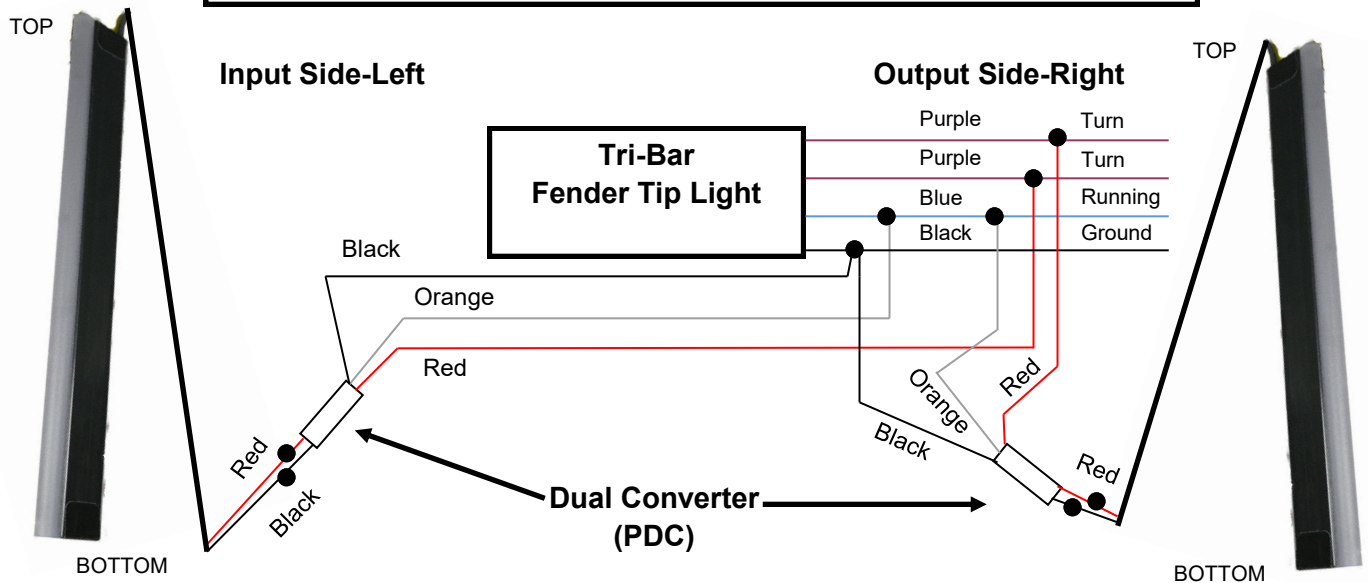

Questions? Call us at: 1 (800) 382-1388 M-TH 8:30AM-5:30PM / FR 9:30AM-5:30PM EST

# Installation Instructions - Page 4

**Plasma Rod™ as Run/Brake/Turn on  
2014-2022 HD Touring with Brake/Turn on the turn signal circuit.**

**MPR-BCM Adapter (Sold Separately)  
Wire Harness Color/Functions  
(note: wiring without MPR see next Page)**

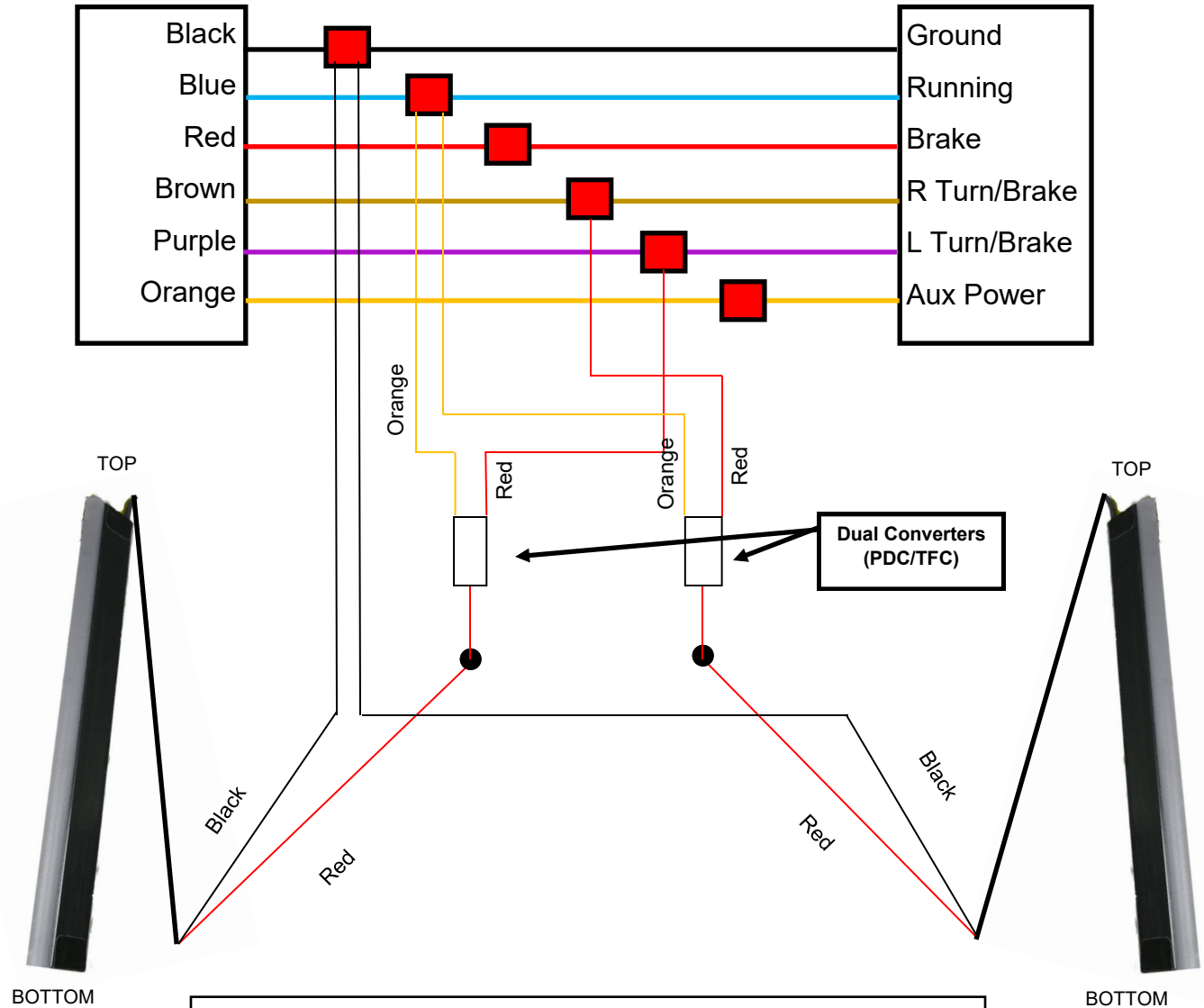

This diagram demonstrates run/brake/turn with the MPR-BCM adapter and (2) TFC dual converters (each sold separately). Other Functions available:

Brake/Turn - Using the MPR-BCM and omitting the dual converters.

Run/Brake - Using the BCM and dual converters connecting the orange wire from the dual converter to the Blue wire, and the red wire from the dual converter to the Red wire in the MPR.

2014-2020 HD motorcycles do not need a Smart Signal Stabilizer™ or a load equalizer when removing stock turn signals.

Questions? Call us at: 1 (800) 382-1388 M-TH 8:30AM-5:30PM / FR 9:30AM-5:30PM EST

# Installation Instructions - Page 5

**Plasma Rod™ as Run/Brake/Turn on  
2014-2022 HD Touring with Brake/Turn on the turn signal circuit.**

**Stock Wire Harness Color/Functions  
(note: only when not using MPR harness adapter)**

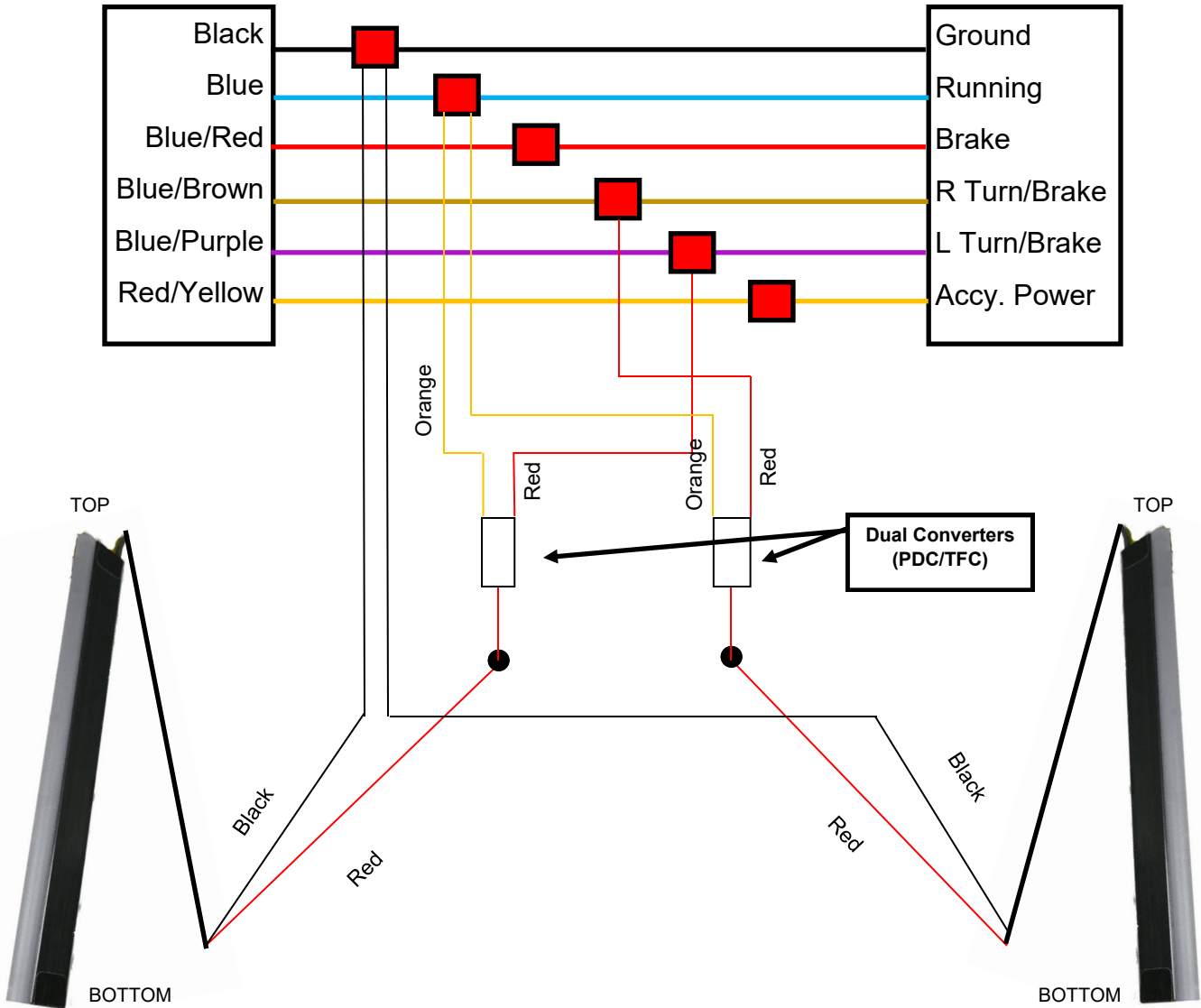

Note: This diagram demonstrates run/brake/turn with (2) TFC dual converters (each sold separately). Plasma rods™ without the dual converters installed will do brake and turn only.